

CVW Valve Series

Characterized Valve for Hydronic Applications

Technical Document

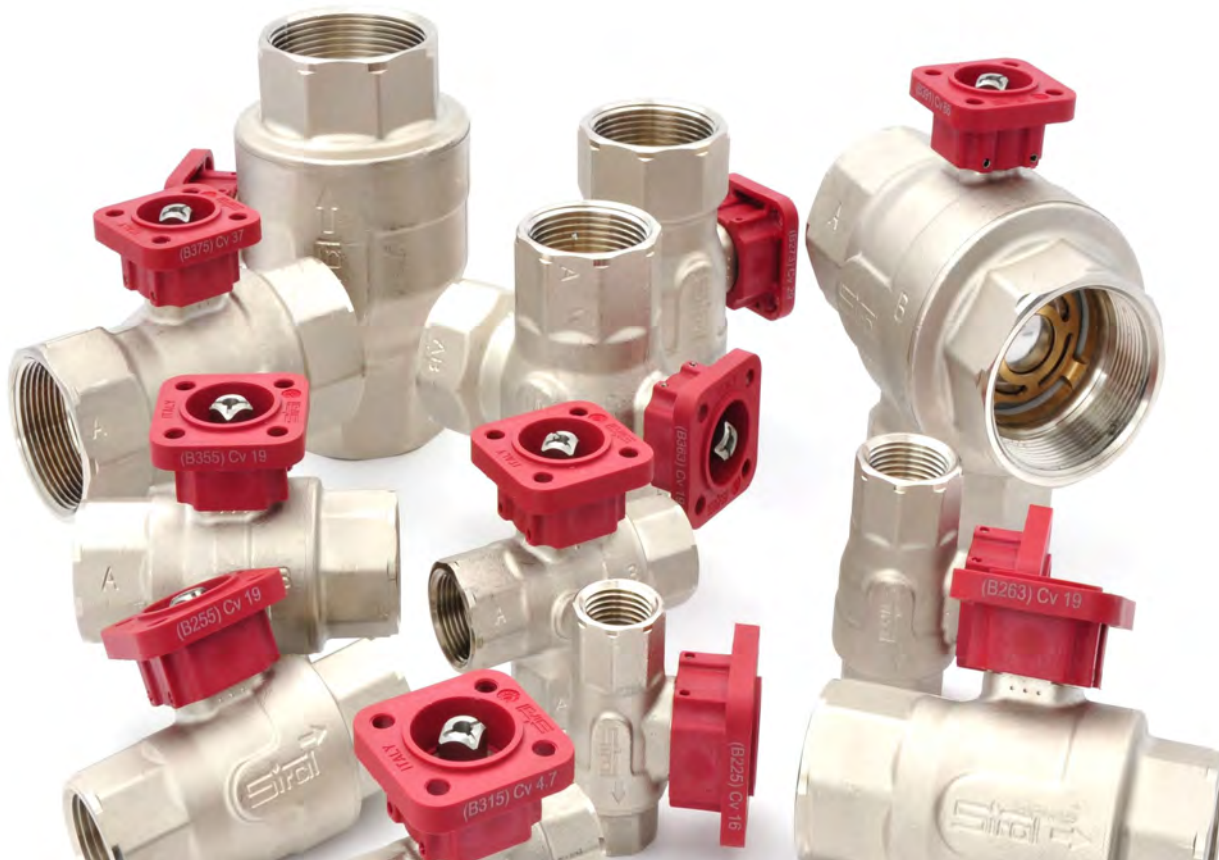

Contents

Overview	2	CVW Valve Series.	6
Stability and Control	2	NC24 Actuator Series.	7
Design	2	V-NDV24 Actuator Series	8
Ball valve Technology	2	V-NFV24 Actuator Series	9
Snapshot	2	FC24 Actuator Series	10
2-Way Flow-Pressure Chart	3	V-FDV24 Actuator Series	11
3-Way Flow-Pressure Chart	4	V-FFV24 Actuator Series	12
Nomenclature	5	Dimensions Non-Spring Return	13
Valve-Actuator Combinations	5	Dimensions Spring-Return (Fail-Safe)	14
		Terms and Conditions.	15 - 17

Overview

The CVW is a characterized control ball valve designed specifically to improve the overall capabilities of a control valve. The CVW sets new standards in control accuracy, leakage efficiency and life durability.

Stability and Control

- The valve's equal percentage characteristic provides a linear change in thermal output based on the valve's opening angle that is controlled by the actuator's input signal.
- With its ball design and built-in brass disc, the CVW is designed to provide durability and flow accuracy that can not be achieved in other plastic disks.
- The brushless DC motor technology has longer life due to its low friction design.
- The valve is designed with efficiency in mind. It incorporates a leak-free auto-cleaning ball assembly. Its thermal barrier flange reduces heat-transfer to the actuator extending its life.
- Internal leakage in a valve causes energy waste. Most 3-way valves in the industry usually have some level of internal leakage even when new. With our unique valve design both our 2-way and 3-way valves are bubble tight with zero leakage through all ports.
- Brushless motor technology improves efficiency due to reduced heat output compared to conventional motors.
- The CVW has a large range of Cv options for each valve size. This reduces installation costs created by multiple pipe reductions.

Design

- Stainless steel or chrome plated brass ball and stem – Maximum corrosion resistance
- Nickel plated brass body –Reduces stress concentration
- Engineered thermal barrier
- Brush-less DC Motor technology

Ball valve Technology

- Self cleaning ball – Eliminates blockage and leakage caused by damaged surfaces
- Blowout proof stem – Safety during system pressure spikes
- Floating seat design – Stable torque through life
- Zero Internal leakage 2-way & 3-way – Stops energy waste caused by leakage.

Snapshot

- Flow patterns: 2-Way, 3-way (Mixing/Diverting)
- Size range: ½ to 2"
- C_v range: 0.3 to 230
- Control: On/Off, Floating Point, Modulating (2-10VDC)

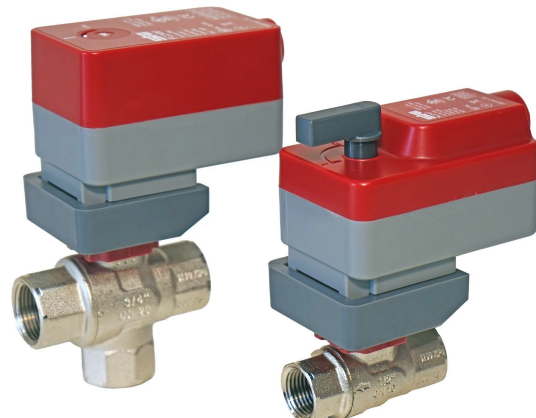

CVW Valve Series

Technical Document



2-Way Flow-Pressure Chart

Gallons per minute flow rate for water applications based on different pressure drops

Valve		Model	CV	Δ Pressure (psid)									
Inch	DN	2-Way		1	2	3	4	5	6	7	8	9	10
½	15	B203	0.3	0.3	0.4	0.5	0.6	0.7	0.7	0.8	0.8	0.9	0.9
		B205	0.46	0.5	0.7	0.8	0.9	1.0	1.1	1.2	1.3	1.4	1.5
		B207	0.8	0.8	1.1	1.4	1.6	1.8	2.0	2.1	2.3	2.4	2.5
		B209	1.2	1.2	1.7	2.1	2.4	2.7	2.9	3.2	3.4	3.6	3.8
		B211	1.9	1.9	2.7	3.3	3.8	4.2	4.7	5.0	5.4	5.7	6.0
		B213	3	3.0	4.2	5.2	6.0	6.7	7.3	7.9	8.5	9.0	9.5
		B215	4.7	4.7	6.6	8.1	9.4	11	12	12	13	14	15
		B218	7.4	7.4	10	13	15	17	18	20	21	22	23
		B221	10	10	14	17	20	22	24	26	28	30	32
B225	16	16	23	28	32	36	39	42	45	48	51		
¾	20	B233	4.7	4.7	6.6	8.1	9.4	11	12	12	13	14	15
		B236	7.4	7.4	10	13	15	17	18	20	21	22	23
		B239	10	10	14	17	20	22	24	26	28	30	32
		B241	14	14	20	24	28	31	34	37	40	42	44
		B243	24	24	34	42	48	54	59	63	68	72	76
1	25	B251	7.4	7	10	13	15	17	18	20	21	22	23
		B253	10	10	14	17	20	22	24	26	28	30	32
		B255	19	19	27	33	38	42	47	50	54	57	60
		B257	30	30	42	52	60	67	73	79	85	90	95
1 ¼	32	B261	10	10	14	17	20	22	24	26	28	30	32
		B263	19	19	27	33	38	42	47	50	54	57	60
		B265	25	25	35	43	50	56	61	66	71	75	79
		B267	37	37	52	64	74	83	91	98	105	111	117
1 ½	40	B271	19	19	27	33	38	42	47	50	54	57	60
		B273	29	29	41	50	58	65	71	77	82	87	92
		B275	37	37	52	64	74	83	91	98	105	111	117
		B277	46	46	65	80	92	103	113	122	130	138	145
2	50	B282	29	29	41	50	58	65	71	77	82	87	92
		B285	37	37	52	64	74	83	91	98	105	111	117
		B287	46	46	65	80	92	103	113	122	130	138	145
		B289	57	57	81	99	114	127	140	151	161	171	180
		B291	66	66	94	115	133	148	161	175	187	198	209
		B294	85	85	120	147	170	190	208	225	240	255	269
		B296	120	120	170	208	240	268	294	317	339	360	379
		B299	230	230	339	416	480	537	588	635	679	720	759

CVW Technical Document Ver. 1.00-E Subject to change. © Siral USA LLC.



3-Way Flow-Pressure Chart

Gallons per minute flow rate for water applications based on different pressure drops

Valve		Model	CV	Δ Pressure (psid)									
Inch	DN	3-Way		1	2	3	4	5	6	7	8	9	10
½	15	B303	0.3	0.3	0.4	0.5	0.6	0.7	0.7	0.8	0.8	0.9	0.9
		B305	0.46	0.5	0.7	0.8	0.9	1.0	1.1	1.2	1.3	1.4	1.5
		B307	0.8	0.8	1.1	1.4	1.6	1.8	2.0	2.1	2.3	2.4	2.5
		B309	1.2	1.2	1.7	2.1	2.4	2.7	2.9	3.2	3.4	3.6	3.8
		B311	1.9	1.9	2.7	3.3	3.8	4.2	4.7	5.0	5.4	5.7	6.0
		B313	3	3.0	4.2	5.2	6.0	6.7	7.3	7.9	8.5	9.0	9.5
		B315	4.7	4.7	6.6	8.1	9.4	11	12	12	13	14	15
¾	20	B318	7.4	7.4	10	13	15	17	18	20	21	22	23
		B333	4.7	4.7	6.6	8.1	9.4	11	12	12	13	14	15
		B336	7.4	7.4	10	13	15	17	18	20	21	22	23
		B339	10	10	14	17	20	22	24	26	28	30	32
1	25	B341	14	14	20	24	28	31	34	37	40	42	44
		B351	7.4	7	10	13	15	17	18	20	21	22	23
		B353	10	10	14	17	20	22	24	26	28	30	32
1 ¼	32	B355	19	19	27	33	38	42	47	50	54	57	60
		B361	10	10	14	17	20	22	24	26	28	30	32
		B363	19	19	27	33	38	42	47	50	54	57	60
		B365	25	25	35	43	50	56	61	66	71	75	79
1 ½	40	B366	35	35	50	63	74	83	91	98	105	111	117
		B371	19	19	27	33	38	42	47	50	54	57	60
		B373	29	29	41	50	58	65	71	77	82	87	92
2	50	B374	35	35	50	63	74	83	91	98	105	111	117
		B382	29	29	41	50	58	65	71	77	82	87	92
		B385	37	37	52	64	74	83	91	98	105	111	117
		B387	46	46	65	80	92	103	113	122	130	138	145
		B389	57	57	81	99	114	127	140	151	161	171	180
		B391	66	66	94	115	133	148	161	175	187	198	209
B393	85	85	120	147	170	190	208	225	240	255	269		

Nomenclature

Valve			Actuator				
B2	98		+NC	24	M	-T	-S
Flow Style	CV Code	Trim	Non Fail-Safe	Power Supply	Control Signal	Electric Connection	Auxiliary
B2 = 2-Way	03 - 99	B = Brass	NC	24 VAC	M = Modulate	-T = Terminal	-S = Switch**
B3 = 3-Way		Blank = Stainless S.	V-NDV	120 VAC	F = Float	Blank = 3 ft. *	Blank = No Switch
			V-NFV	240 VAC	= On/Off		

Normal Position (Non-Fail-Safe)
NC= Normally Closed
NO= Normally Open

Normal Position (Fail-Safe)
NC/FC= Normally Closed, Fail Closed
NO/FC= Normally Open, Fail Closed
NC/FO= Normally Closed, Fail Open
NO/FO= Normally Open, Fail Open

Fail-Safe
FC
V-FDV
V-FFV

**Switch option available for FC, V-ND, V-NF and V-FF Series only

Valve-Actuator Combinations

Valve					Actuator	
Inches	DN (mm)	Cv	2-Way	3-Way	Non-Fail Safe	Fail Safe
1/2"	15	0.3	B203(B)	B303	NC - Series	FC - Series
		0.46	B205(B)	B305		
		0.8	B207(B)	B307		
		1.2	B209(B)	B309		
		1.9	B211(B)	B311		
		3	B213(B)	B313		
		4.7	B215(B)	B315		
		7.4	B218(B)	B318		
		10	B221(B)			
		16	B225(B)			
3/4"	20	4.7	B233(B)	B333	NC - Series	FC - Series
		7.4	B236(B)	B336		
		10	B239(B)	B339		
		14	B241(B)	B341		
		24	B243(B)			
		35	B245*			
1"	25	7.4	B251(B)	B351	V-ND - Series	V-FD - Series
		10	B253(B)	B353		
		19	B255(B)	B355		
		30	B257(B)			
		53	B259*			
		10	B261(B)	B361		
1.25"	32	19	B263(B)	B363	V-ND - Series	V-FD - Series
		25	B265(B)	B365		
		35		B366		
		37	B267(B)			
		120	B269*			
		19	B271(B)	B371		
1.5"	40	29	B273(B)	B373	V-ND - Series	V-FD - Series
		35		B374		
		37	B275(B)			
		46	B277(B)			
		90	B279*			
		29	B282(B)	B382		
2"	50	37	B285(B)	B385	V-NF - Series	V-FF - Series
		46	B287(B)	B387		
		57	B289(B)	B389		
		66	B291(B)	B391		
		85	B294(B)	B393		
		120	B296(B)			
		230	B299(B)			

CVW Valve Series

Characterized Ball Valve (Stainless-Steel Ball and Stem)
 2-Way, 3-Way Mixing, and 3-Way Diverting
 Sizes: ½" to 2" NPT



Specification		
Sizes [DN]		½" to 2" [15 to 50]
C_v	Range	0.3 to 230
Media	Type	Water, Glycol 60%
	Temperature	0°F to 250°F [-18°C to 120°C]
Pressure	Body	(½" to 1") 600 psi, (1-1/4" to 2") 400 psi
	Close-Off	200 psi
	Differential (ΔP)	50 psid
Leakage	A-AB Port	0%
	B Port	0%
	Rating	according to EN 12266-1:2003
Materials	Body	Nickle-Plated Forged Brass
	Ball and Stem	Stainless-Steel or Chrome plated Brass
	Seats	PTFE
	Characterized Disc	Brass (½" to 2")
	Stem O-Rings	EPDM Perox
Flow	Curve	Equal %
	Pattern	2-Way, 3-Way mixing, 3-Way diverting
	Control Angle	75°
Rangeability		100 : 1
Valve	Connection	Female NPT



Application

The CVW series of characterized ball valves provide accurate flow control in hydronic HVAC applications. Its equal percentage flow characteristic curve is typically used in air handling coils, chilled beams, fancoils, unit ventilators, VAV reheat-coils, and bypass piping.

Operation

The CVW valve is designed to provide leak-free operation throughout its life. It is equipped with an equal percentage characterized brass disc to provide accurate long lasting performance. The valve comes in three different flow patterns: 2-way, 3-way mixing, and 3-way diverting.

Flow Pattern (2-Way)

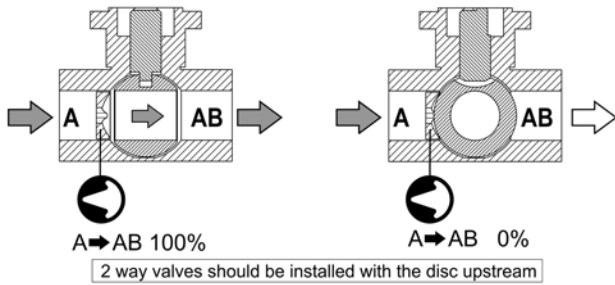

Flow Pattern (3-Way)

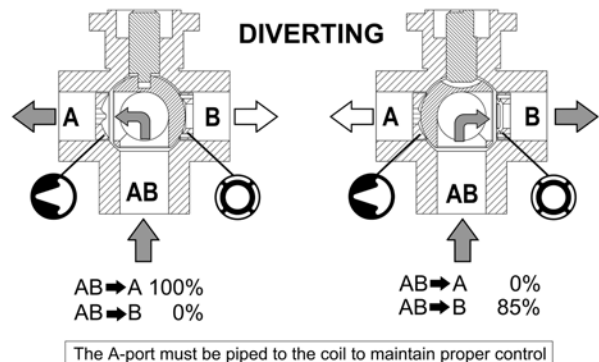
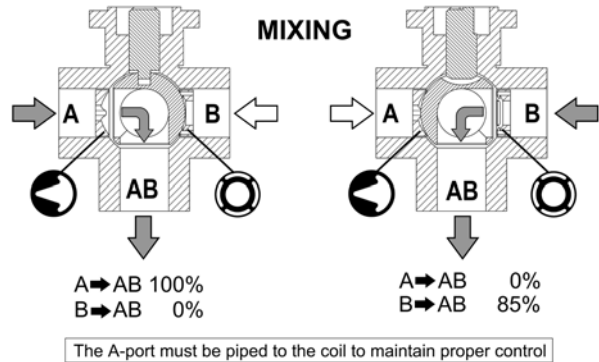

CVW Technical Document Ver. 1.00-E Subject to change. © Siral USA LLC.

NC24 Actuator Series

On/Off Floating , Modulating



Non-Fail -Safe

Specification		NC24F	NC24M
Control	Signal	On/Off Floating (3-Point)	Modulating 2 -10VDC
Power	Voltage AC	24 VAC 50/60 Hz ± 20%	
	Voltage DC	24 VDC ± 10%	24 VDC ± 10%
	Overload Protection	Electronic	Electronic
	Consumption	0.5 W	0.5 W
	Transformer	1 VA (Class 2)	1 VA (Class 2)
	Connection	Plenum rated cable 22 AWG: 3 ft (1 m)	
Operation	Run time (Motor)	75 Seconds	
	Manual Override	Push down handle	
	Rotation Angle	90°, tool free field adjustable mechanical stops	
	Rotation Direction	Jumper Switch CW/CCW factory set	
	Position Indicator	Visual Pointer	
	Noise	35dBA	
Housing	Protection	NEMA 2 / IP42	
	Rating	UL94-5V (B)	
Temp.	Ambient	-0°F to 122°F (-18°C to 50°C)	
	Storage	-22°F to 122°F (-30°C to 50°C)	
	Humidity	5 to 95% non-condensing	
Agency Listing		cULus UL 60730-1A/-2-14	
		CAN/CAS E60730-1:2	
		CE according to 2004/108/EC and 2006/95/EC for line voltage	

On/Off, Floating Point: **NC24F**
 Modulating with Feedback: **NC24M**



WARNING

Actuator must be installed by licensed or electrically trained technician. Failure to follow electrical safety precaution when working with live electrical connection could result in injury or death.

On/Off, Floating Wiring

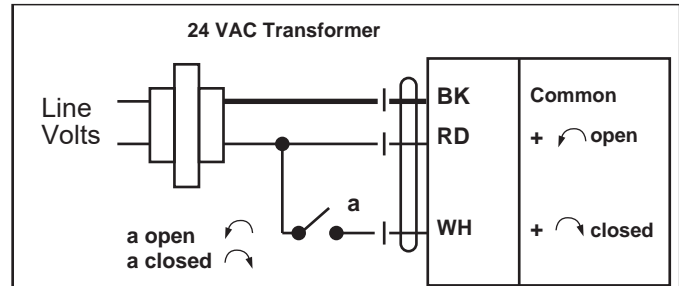

On/Off Control

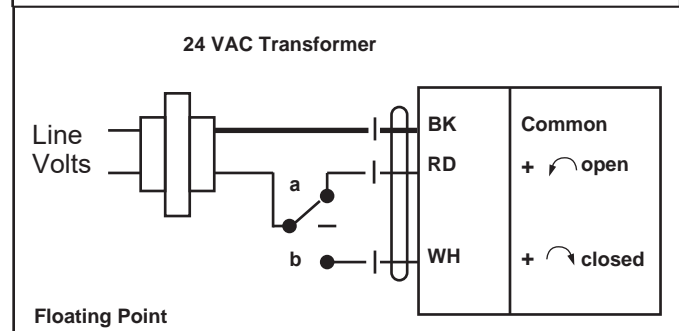

Floating Point

Modulating Wiring

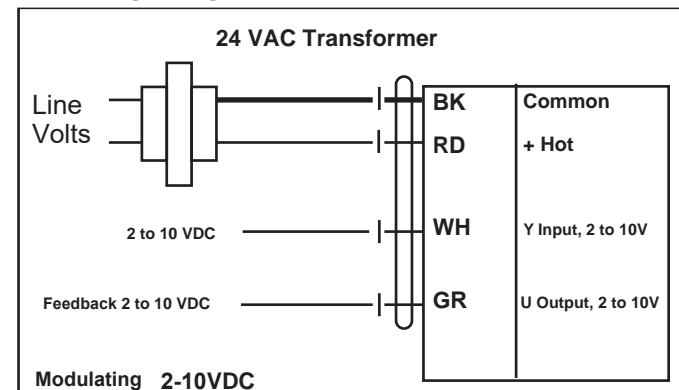

Modulating 2-10VDC

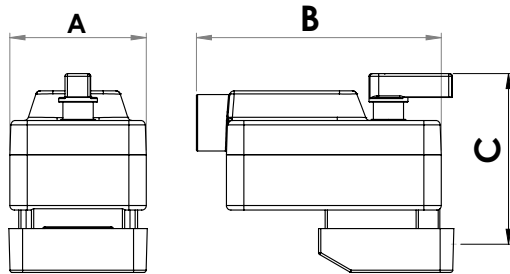

Dimensions					
A		B		C	
inch	mm	inch	mm	inch	mm
2.35	59.69	4.45	113.00	2.99	76.00

V-NDV24 Actuator Series

On/Off, Floating (3-Point), Modulating
Non-Spring Return



Specification		(F) Floating, On/Off †	(M) Modulating †
Control	Signal	On/Off, Floating (3-Point)	2-10 VDC
	Input Impedance	600 Ω	100 kΩ
	Feedback Signal		1-10 VDC
Power	Voltage AC	24 VAC 50/60 Hz ± 20%	
	Voltage DC	24 VDC ±10%	
	Overload Protection	Electronic overload protection	
	Consumption Running	1.5 W	1.5 W
	Consumption Holding	0.2 W	0.4 W
	Transformer	2 VA (Class 2)	3 VA (Class 2)
	Connection	Terminals, Plenum rated cable 18 GA: 3 Ft. (1 m), 10 Ft. (3 m)	
Operation	Runtime (Motor)	90 seconds	
	Manual Override	Push-button	
	Rotation Angle	90°, adjustable using Screwed tabs	
	Rotation Direction	Direction Switch ↺ ↻	
	Position Indicator	Manual Knob	
	Noise	35 dBA	
Housing	Protection	NEMA 1 / IP40	
	Rating	UL94-5V (B)	
Temp.	Ambient	-22°F to 122°F (-30°C to 50°C)	
	Storage	-40°F to 176°F (-40°C to 80°C)	
	Humidity	5 to 95% non-condensing	
Agency Listing	<ul style="list-style-type: none"> • cULus UL 60730-1A/-2-14, • CAN/CSA E60730-1:02, • CE according to 2004/108/EC and 2006/95/EC for line voltage 		

† Rated impulse voltage 800V, Control pollution degree 3, Type of action 1

Floating, On/Off: **V-NDV24F**
Modulating: **V-NDV24M**



WARNING



Actuator must be installed by licensed or electrically trained technician. Failure to follow electrical safety precaution when working with live electrical connection could result in injury or death.

Floating and On/Off Wiring

Meets cULus or UL and CSA requirements without the need of an electrical ground connection.

Wiring

Modulating Wiring

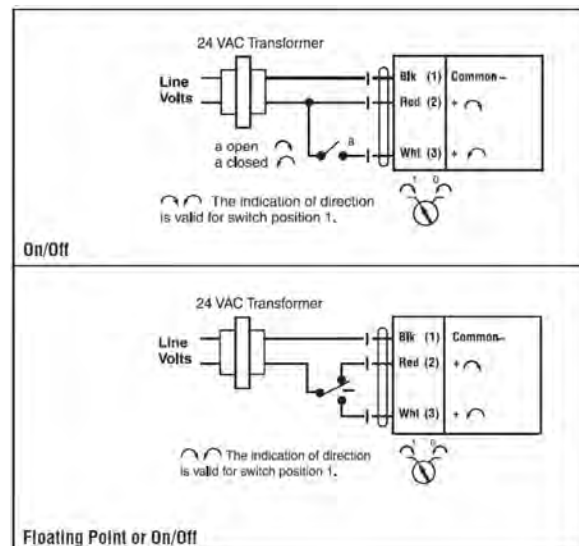
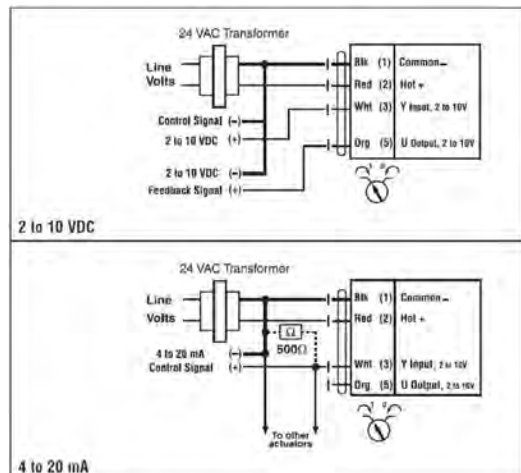

V-NFV24 Actuator Series

On/Off, Floating (3-Point), Modulating
Non-Spring Return



Specification		(F) Floating, On/Off †	(M) Modulating †
Control	Signal	On/Off, Floating (3-Point)	2-10 VDC
	Input Impedance	600 Ω	100 kΩ
	Feedback Signal		1-10 VDC
Power	Voltage AC	24 VAC 50/60 Hz ± 20%	
	Voltage DC	24 VDC ±10%	
	Overload Protection	Electronic overload protection	
	Consumption Running	2.5 W	2.5 W
	Consumption Holding	0.2 W	0.4 W
	Transformer	6 VA (Class 2)	5 VA (Class 2)
	Connection	Terminals, Plenum rated cable 18 GA: 3 Ft. (1 m), 10 Ft. (3 m)	
Operation	Runtime (Motor)	90 seconds	
	Manual Override	Push-button	
	Rotation Angle	90°, adjustable using Screwed tabs	
	Rotation Direction	Direction Switch ↺ ↻	
	Position Indicator	Manual Knob	
	Noise	45 dBA	
Housing	Protection	NEMA 2 / IP54	
	Rating	UL94-5VA	
Temp.	Ambient	-22°F to 122°F (-30°C to 50°C)	
	Storage	-40°F to 176°F (-40°C to 80°C)	
	Humidity	5 to 95% non-condensing	
Agency Listing	<ul style="list-style-type: none"> • cULus UL 60730-1A/-2-14, • CAN/CSA E60730-1:02, • CE according to 2004/108/EC and 2006/95/EC for line voltage 		

† Rated impulse voltage 800V, Control pollution degree 3, Type of action 1

Floating, On/Off: V-NFV24F
Modulating: V-NFV24M



WARNING

Actuator must be installed by licensed or electrically trained technician. Failure to follow electrical safety precaution when working with live electrical connection could result in injury or death.

Floating and On/Off Wiring

Meets cULus or UL and CSA requirements without the need of an electrical ground connection.

Wiring

Modulating Wiring

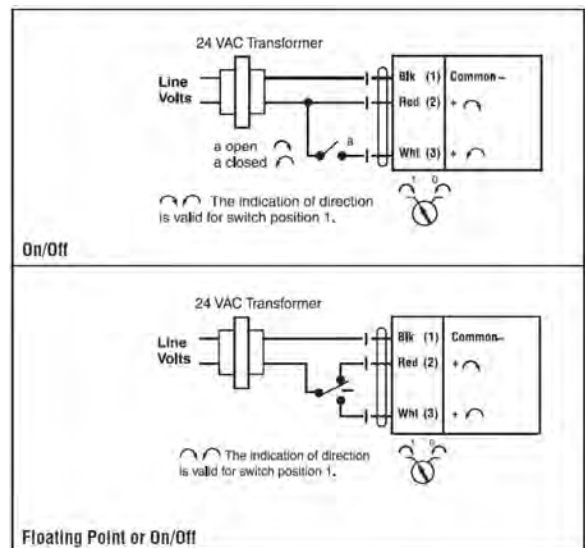
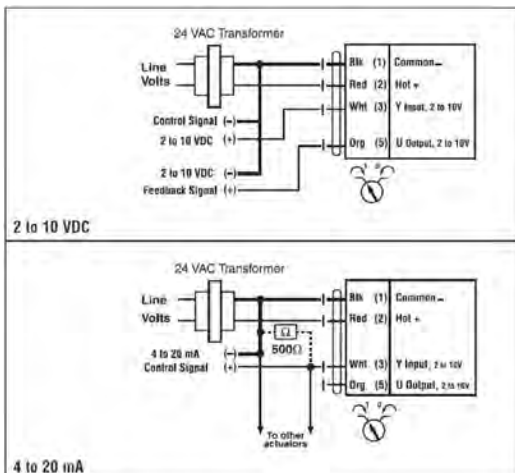

FC24 Actuator Series

On/Off, On/Off + Switch Modulating



Specification		FC24	FC24-S	FC24M
Control	Signal	On/Off	On/Off + Switch	Modulating 2 -10VDC
Power	Voltage AC	24 VAC 50/60 Hz ± 20%		
	Voltage DC	24 VDC ± 10%		
	Overload Protection	Electronic		
	Consumption	1 W	1.5 W	0.5 W
	Transformer	1 VA (Class 2)	2 VA (Class 2)	1 VA (Class 2)
	Connection	Plenum rated cable 18 AWG: 3 ft (1 m)	Plenum rated cable 22 AWG: 3 ft (1 m)	
Operation	Runtime (Motor)	80 Seconds	75 Seconds	
	Runtime (CAP)	50 Seconds		
	Rotation Angle	90°, tool free field adjustable mechanical stops		
	Rotation Direction (Motor)	Jumper Switch CW/CCW, factory set		
	Rotation Direction (CAP)	Jumper Switch CW/CCW, factory set		
	Position Indicator	Visual Pointer		
	Noise Motor	35dBA		
	Noise Motor Cap	35dBA		
Housing	Protection	NEMA 2 / IP42		
	Rating	UL94-5V (B)		
Temp.	Ambient	-0°F to 122°F (-18°C to 50°C)		
	Storage	-22°F to 122°F (-30°C to 50°C)		
	Humidity	5 to 95% non-condensing		
Agency Listing		cULus UL 60730-1A/-2-14		
		CAN/CAS E60730-1:2		
		CE according to 2004/108/EC and 2006/95/EC for line voltage		

On/Off: **FC24**
 On/Off, Auxiliary Switch: **FC24-S**
 Modulating with Feedback: **FC24M**



WARNING

Actuator must be installed by licensed or electrically trained technician. Failure to follow electrical safety precaution when working with live electrical connection could result in injury or death.

On/Off Wiring

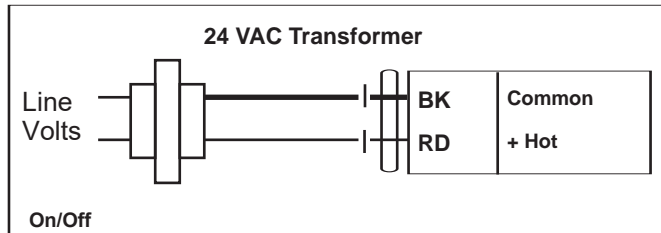

On/Off, Auxiliary Switch Wiring

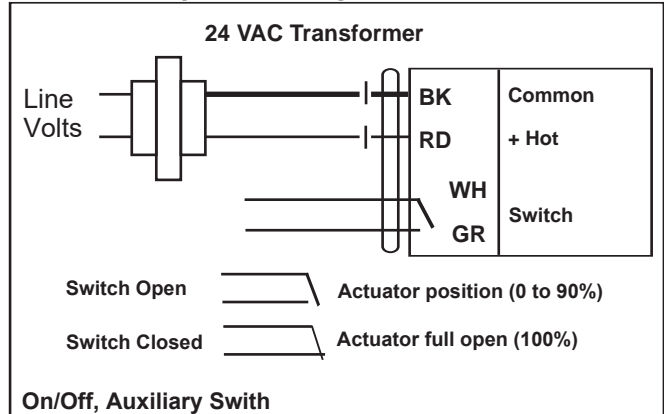

Modulating Wiring

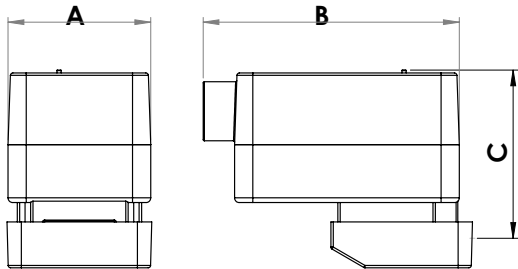
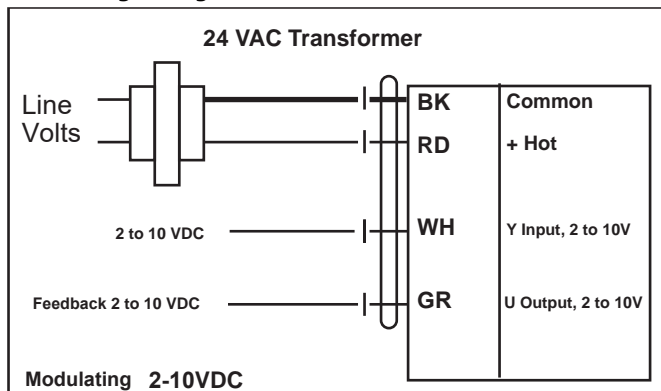

Dimensions					
A		B		C	
inch	mm	inch	mm	inch	mm
2.35	59.69	4.22	106.68	2.77	70.35

CVW Technical Document Ver. 1.00-E Subject to change. © Siral USA LLC.

V-FDV24 Actuator Series

On/Off, Floating (3-Point), Modulating
Spring-Return (Fail-Safe)



Specification		On/Off [†]	(F) Floating [†]	(M) Modulating [†]
Control	Signal	On/Off	Floating (3-Point)	2-10 VDC
	Input Impedance		1000 Ω	100 kΩ
Power	Voltage AC	24 VAC 50/60 Hz ± 20%		
	Voltage DC	24 VDC ±10%		24 VDC ±10%
	Overload Protection	Electronic overload protection		
	Consumption Running	2.5 W		
	Consumption Holding	1.3 W	1 W	
	Transformer	5 VA (Class 2)	4 VA (Class 2)	
	Connection	<ul style="list-style-type: none"> Terminals, Plenum rated cable 18 GA: 3 Ft. (1 m), 10 Ft. (3 m) 		
Operation	Runtime (Motor)	<40 to 75 sec	150 sec	
	Runtime (Spring)	<75 sec @ -22°F to 122°F [-20°C to 50°C]	<25 sec @ -4°F to 122°F [-20°C to 50°C]	<60 sec @ -22°F [-30°C]
	Manual Override	Push-button		
	Rotation Angle	95°, adjustable using Screwed tabs		
	Rotation Direction (Motor)	Direction Switch		
	Rotation Direction (Spring)	Reversible with CW/CCW mounting		
	Position Indicator	Visual		
	Noise Motor	<50 dBA	<30 dBA	
	Noise Spring	<62 dBA	<62 dBA	
	Housing	Protection	NEMA 2 / IP42	
Rating		UL94-5VA		
Temp.	Ambient	-22°F to 122°F (-30°C to 50°C)		
	Storage	-40°F to 176°F (-40°C to 80°C)		
	Humidity	5 to 95% non-condensing		
Agency Listing	<ul style="list-style-type: none"> cULus UL 60730-1A/-2-14, CAN/CSA E60730-1:02, 			

[†] Rated impulse voltage 800V, Control pollution degree 3, Type of action 1.AA

Wiring

On/Off Wirin

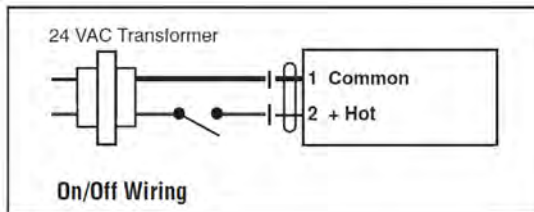

Actuators may also be powered by 24 VDC.

On/Off: V-FDV24
Floating: V-FDV24F
Modulating: V-FDV24M



WARNING

Actuator must be installed by licensed or electrically trained technician. Failure to follow electrical safety precaution when working with live electrical connection could result in injury or death.

Floating Wiring

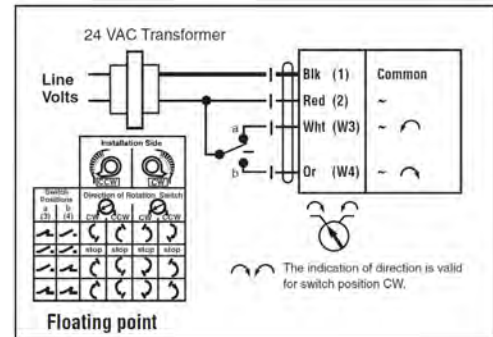

Modulating Wiring

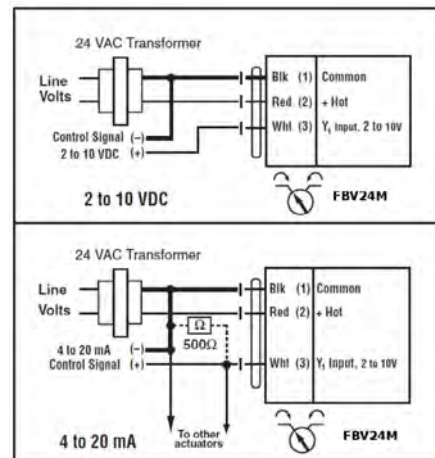

V-FFV24 Actuator Series

On/Off, Modulating
Spring-Return (Fail-Safe)



Specification	On/Off†	(M) Modulating†	
Control	Signal	On/Off	2-10 VDC
	Input Impedance		100 kΩ (2-10VDC)
	Feedback Signal		2-10 VDC
Power	Voltage AC	24 VAC 50/60 Hz ± 20%	
	Voltage DC	24 VDC +20%/-10%	
	Overload Protection	Electronic overload protection	
	Consumption Running	5 W	5.5 W
	Consumption Holding	2.5 W	3 W
	Transformer	7.5 VA (Class 2)	8.5 VA (Class 2)
	Connection	<ul style="list-style-type: none"> Terminals, Plenum rated cable 18 GA: 3 Ft.(1 m), 10 Ft. (3 m) 	
Operation	Runtime (Motor)	< 75 seconds	95 seconds
	Runtime (Spring)	< 75 sec @ -22°F to 122°F [-20°C to 50°C]	< 20 sec @ -4°F to 122°F [-20°C to 50°C] < 60 sec @ -22°F [-30°C]
	Manual Override	Hex Crank (5mm)	
	Rotation Angle	95°, adjustable using Screwed tabs	
	Rotation Direction (Motor)	Wire Polarity	Direction Switch
	Rotation Direction (Spring)	Reversible with CW/CCW mounting	
	Position Indicator	Visual	
	Noise Motor	< 50 dBA	< 40 dBA
	Noise Spring	< 62 dBA	
	Housing	Protection	NEMA 2 / IP54
Rating		UL94-5VA	
Housing Material		zinc coated metal and plastic casing	
Temp.	Ambient	-22°F to 122°F (-30°C to 50°C)	
	Storage	-40°F to 176°F (-40°C to 80°C)	
	Humidity	5 to 95% non-condensing	
Agency Listing	<ul style="list-style-type: none"> cULus UL 60730-1A/-2-14, CAN/CSA E60730-1:02, 		

† Rated impulse voltage 800V, Control pollution degree 3, Type of action 1.AA

Wiring

On/Off Wirin

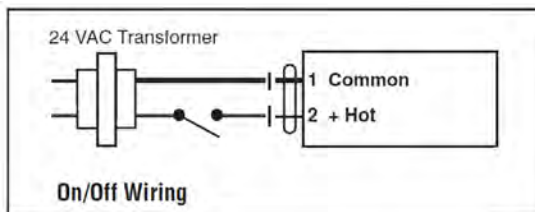

Actuators may also be powered by 24 VDC.

On/Off: V-FFV24
Modulating: V-FFV24M



WARNING

Actuator must be installed by licensed or electrically trained technician. Failure to follow electrical safety precaution when working with live electrical connection could result in injury or death.

Modulating Wiring

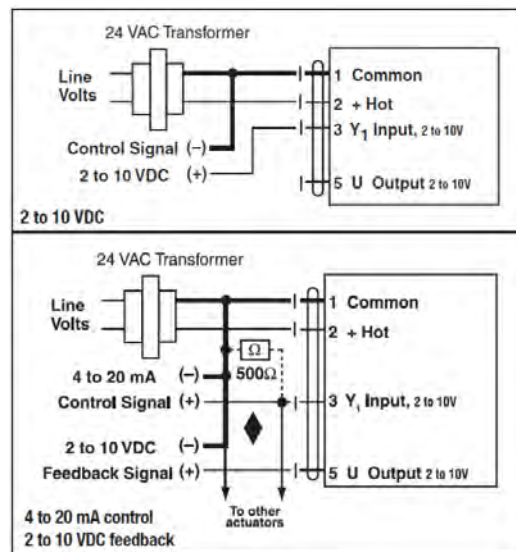

Dimensions Non-Spring Return (Inches [mm])



Actuator (NC24) with 2-Way CVW

Valve	Size	DN	A	B	C	C	E
B203-B211	1/2"	10	3.6 [91.5]	2.38 [60.5]	4.77 [121.2]	4.25 [108]	0.89 [22.5]
B213-B225	1/2"	15	3.72 [94.5]	2.66 [67.5]	4.85 [123.2]	4.25 [108]	0.89 [22.5]
B233-B243	3/4"	20	3.92 [99.5]	3.01 [76.5]	5.18 [131.5]	4.41 [112]	0.89 [22.5]

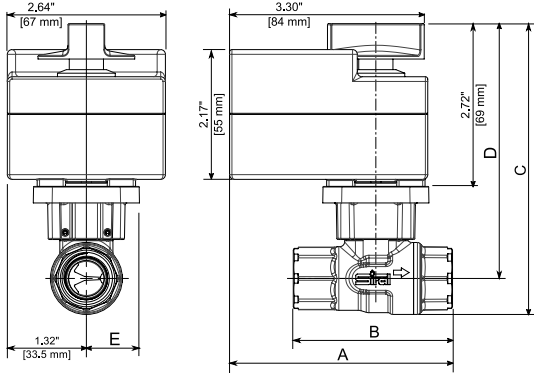

Actuator (NC24) with 3-Way CVW

Valve	Size	DN	A	B	C	C	E
B303-B311	1/2"	10	3.66 [93]	2.44 [62]	5.47 [139]	4.25 [108]	0.89 [22.5]
B313-B318	1/2"	15	3.82 [97]	2.76 [70]	5.57 [141.5]	4.25 [108]	0.89 [22.5]
B333-B341	3/4"	20	4.07 [103.5]	3.17 [80.5]	5.91 [150]	4.41 [112]	0.89 [22.5]

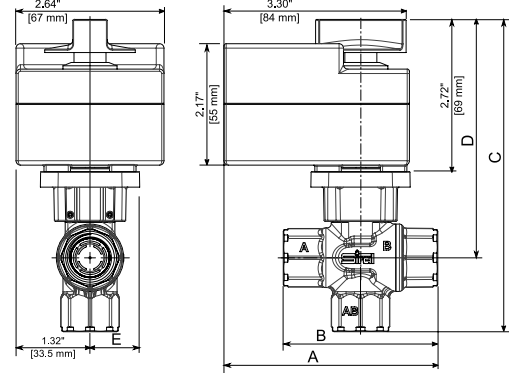

Actuator (V-NDV24) with 2-Way CVW

Valve	Size	DN	A	B	C	C	E
B213-B225	1/2"	15	6.59 [167.5]	2.38 [60.5]	5.36 [136.2]	4.76 [121]	0.89 [22.5]
B233-B243	3/4"	20	6.79 [172.5]	3.01 [76.5]	5.69 [144.5]	4.92 [125]	0.89 [22.5]
B251-B257	1"	25	7.2 [183]	3.78 [96]	6.04 [153.5]	5.1 [129.5]	0.94 [24]
B261-B267	1 1/4"	32	7.32 [186]	4.15 [105.5]	6.63 [168.3]	5.42 [137.8]	1.2 [30.5]
B271-B277	1 1/2"	40	7.52 [191]	4.39 [111.5]	6.63 [168.3]	5.42 [137.8]	1.2 [30.5]

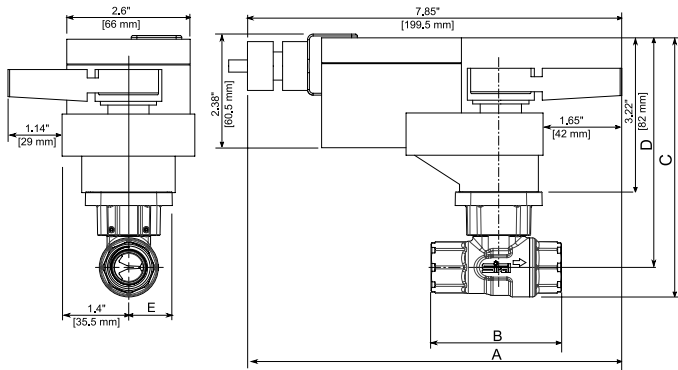

Actuator (V-NDV24) with 3-Way CVW

Valve	Size	DN	A	B	C	C	E
B313-B318	1/2"	15	6.69 [170]	3.17 [80.5]	6.08 [154.5]	4.76 [121]	0.89 [22.5]
B333-B341	3/4"	20	6.95 [176.5]	3.17 [80.5]	6.41 [163]	4.92 [125]	0.89 [22.5]
B351-B355	1"	25	7.22 [183.5]	3.8 [96.5]	6.99 [177.5]	5.1 [129.5]	0.94 [24]
B361-B367	1 1/4"	32	7.52 [191]	4.35 [110.5]	7.67 [194.8]	5.42 [137.8]	1.2 [30.5]
B371-B375	1 1/2"	40	7.52 [191]	4.39 [111.5]	7.67 [194.8]	5.42 [137.8]	1.2 [30.5]

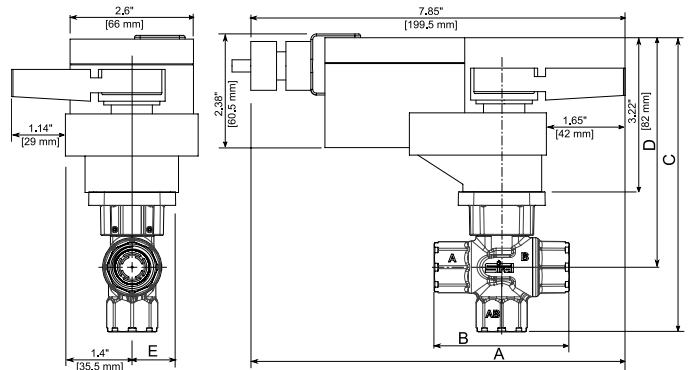

Actuator (V-NFV24) with 2-Way CVW

Valve	Size	DN	A	B	C	C	E
B282-B299	2"	50	9.02 [229.2]	5.52 [140.2]	7.79 [197.8]	6.03 [153.3]	1.75 [44.5]

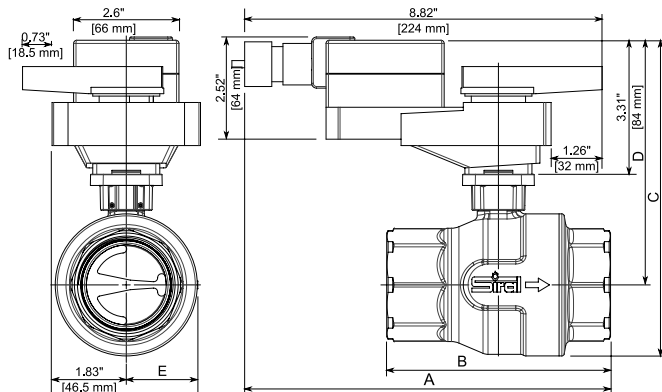

Actuator (V-NFV24) with 3-Way CVW

Valve	Size	DN	A	B	C	C	E
B382-B393	2"	50	9.02 [229.2]	5.52 [140.2]	8.91 [226.3]	6.03 [153.3]	1.75 [44.5]

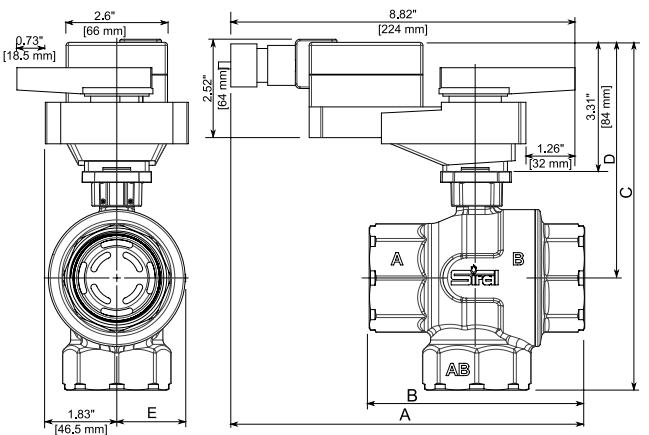

CWV Technical Document Ver. 1.00-E Subject to change. © Siral USA LLC.

Dimensions Spring-Return (Fail-Safe) (Inches [mm])



Actuator (FC24) with 2-Way CVW

Valve	Size	DN	A	B	C	C	E
B203-B211	1/2"	10	6.69 [170]	2.38 [60.5]	5.24 [133.2]	4.72 [120]	0.89 [22.5]
B213-B225	1/2"	15	6.81 [173]	2.66 [67.5]	5.32 [135.2]	4.72 [120]	0.89 [22.5]
B233-B243	3/4"	20	7.01 [178]	3.01 [76.5]	5.65 [143.5]	4.88 [124]	0.89 [22.5]

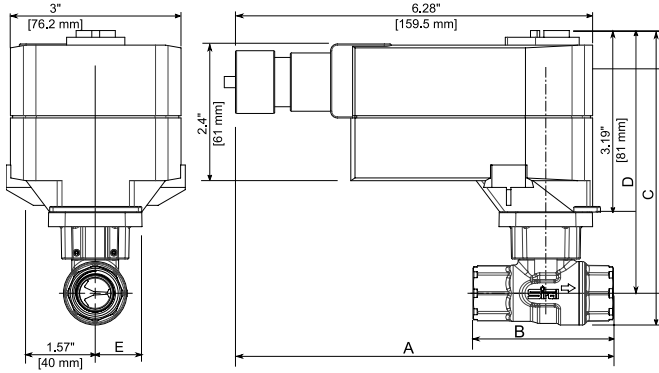

Actuator (FCV24) with 3-Way CVW

Valve	Size	DN	A	B	C	C	E
B303-B311	1/2"	10	6.75 [171.5]	2.44 [62]	5.94 [151]	4.72 [120]	0.89 [22.5]
B313-B318	1/2"	15	6.91 [175.5]	2.76 [70]	6.04 [153.5]	4.72 [120]	0.89 [22.5]
B333-B341	3/4"	20	7.16 [182]	3.17 [80.5]	6.38 [162]	4.88 [124]	0.89 [22.5]

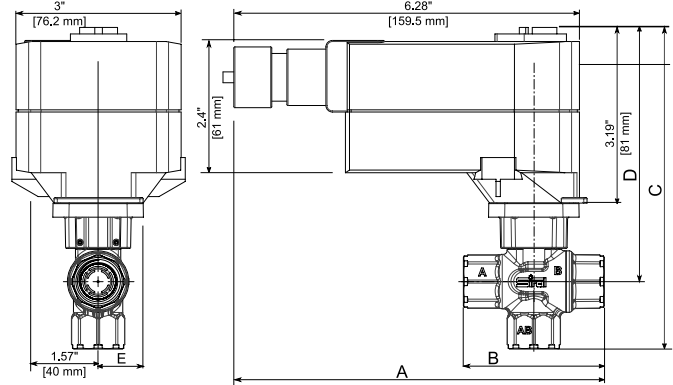

Actuator (V-FDV24) with 2-Way CVW

Valve	Size	DN	A	B	C	C	E
B213-B225	1/2"	15	7.93 [201.5]	2.66 [67.5]	5.6 [142.2]	5 [127]	0.89 [22.5]
B233-B243	3/4"	20	8.13 [206.5]	3.01 [76.5]	5.92 [150.5]	5.16 [131]	0.89 [22.5]
B251-B257	1"	25	8.54 [217]	3.78 [96]	6.28 [159.5]	5.33 [135.5]	0.94 [24]
B261-B267	1 1/4"	32	8.66 [220]	4.15 [105.5]	6.86 [174.3]	5.66 [143.8]	1.2 [30.5]
B271-B277	1 1/2"	40	8.86 [225]	4.39 [111.5]	6.86 [174.3]	5.66 [143.8]	1.2 [30.5]

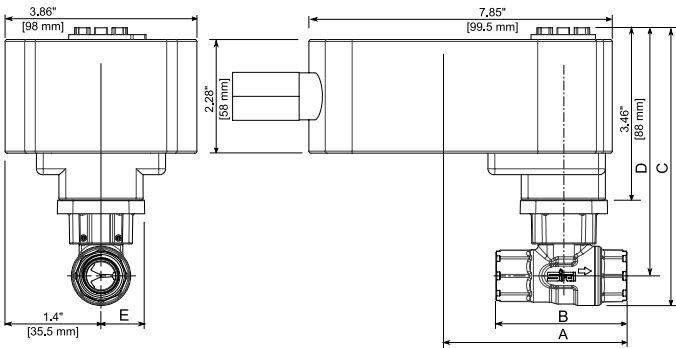

Actuator (V-FDV24) with 3-Way CVW

Valve	Size	DN	A	B	C	C	E
B313-B318	1/2"	15	8.03 [204]	2.76 [70]	6.32 [160.5]	5 [127]	0.89 [22.5]
B333-B341	3/4"	20	8.29 [210.5]	3.17 [80.5]	6.65 [169]	5.16 [131]	0.89 [22.5]
B351-B355	1"	25	8.56 [217.5]	3.8 [96.5]	7.22 [183.5]	5.33 [135.5]	0.94 [24]
B361-B367	1 1/4"	32	8.86 [225]	4.35 [110.5]	7.9 [200.8]	5.66 [143.8]	1.2 [30.5]
B371-B375	1 1/2"	40	8.86 [225]	4.35 [111.5]	7.9 [200.8]	5.66 [143.8]	1.2 [30.5]

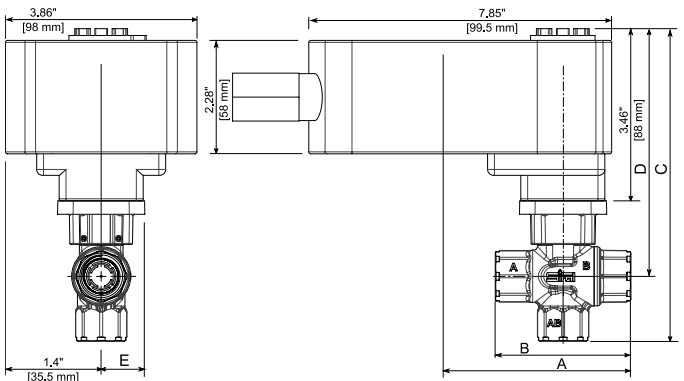

Actuator (V-FFV24) with 2-Way CVW

Valve	Size	DN	A	B	C	C	E
B282-B299	2"	50	10.94 [278]	5.52 [140.2]	8.5 [215.8]	6.74 [171.3]	1.75 [44.5]

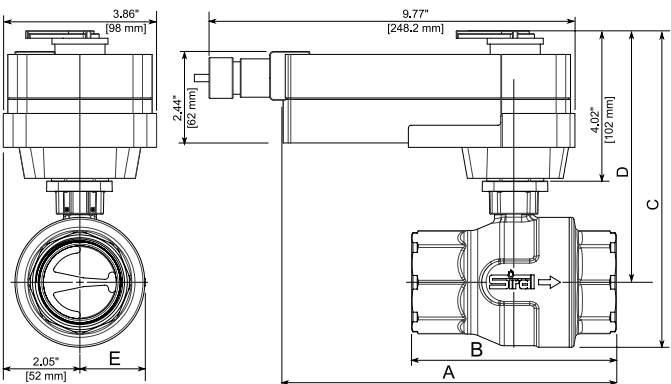

Actuator (V-FFV24) with 3-Way CVW

Valve	Size	DN	A	B	C	C	E
B382-B393	2"	50	10.94 [278]	5.52 [140.2]	9.62 [244.3]	6.74 [171.3]	1.75 [44.5]

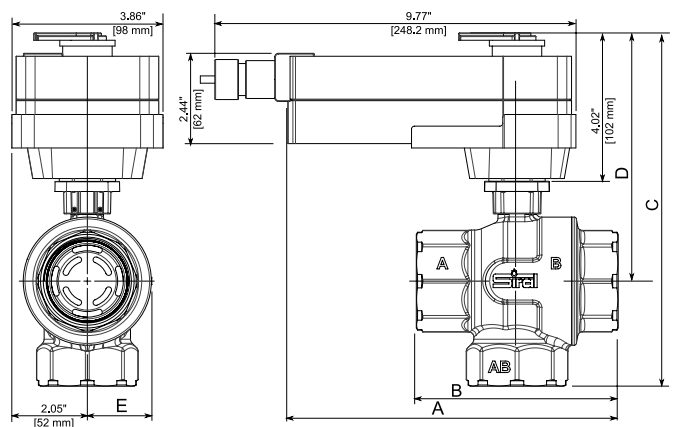

Terms and Conditions

1 Applicable Terms and Conditions of Sale

1.1 These Terms and Conditions of Sale ("Terms") establish the rights, obligations and remedies of "Seller" and "Buyer" which apply to any order issued by Buyer for the purchase of products described in its product guide, catalogs, analytical data and other literature ("Products"). As used herein, "Seller" shall mean Siral, as applicable, and "Buyer" shall mean any party, individual or business entity, who contracts to purchase products from Seller. These Terms shall prevail over any conflicting terms or conditions Buyer may submit at any time, unless otherwise specifically agreed in writing by both Buyer and Seller.

2 Prices

2.1 All prices are in US currency unless otherwise clearly specified in an accepted agreement.

2.2 Prices on products are exclusive of all sales, excise and other taxes, and exclusive of freight, handling and storage charges, any or all of which, as applicable, will be added as separate charges to be paid by the Buyer or otherwise charged as indicated in these Terms. If Seller is required to impose, levy, collect, withhold or assess any such taxes, duties or charges on any transactions, then in addition to the purchase price, Seller will invoice Buyer for such taxes, duties, and charges unless at the time of order placement Buyer provides Seller with an exemption certificate or other documentation sufficient to verify exemption from such taxes, duties or charges.

2.3 Seller reserves the right to change its prices if from the time of quotation (a) raw material and/or component prices have changed; or (b) actual volume is less than forecast volume; or (c) there is any significant change in economic circumstance; or modifications requested by Buyer give rise to additional costs.

2.4 Price quotations are effective for thirty (30) days subsequent to the date at which the quotation is given. Unless otherwise agreed by Seller in writing, price quotations provided by Seller are not intended as and shall not be construed as constituting an offer to Buyer. Any prices provided by Seller is subject to, and shall not become binding upon Seller until, (a) actual receipt by Seller of Buyer's written order based on all the terms and conditions stated herein, without qualification, within thirty (30) days after the date of the price quotation, and (b) Seller's written acceptance of such order.

2.5 Unless otherwise specified by Seller, all prices are F.O.B. Point of Origin from which shipment is made and payment terms will be net thirty (30) days from date of invoice.

2.6 Buyer will be charged a handling fee of US \$20 for all orders with a net value of less than US \$300. Freight, expedited fees or any other shipping charges shall be paid by Buyer and are in addition to the price of goods within the order including Buyer's minimum order charge.

3 Delivery

3.1 All delivery dates are approximate, and Seller shall not be responsible for any damages or losses of any kind resulting from any delay. Unless otherwise agreed by Seller, Seller may exercise its judgment in choosing the carrier and means of delivery. No deferment of shipment at Buyer's request beyond the respective dates indicated in Buyer's orders shall be made except on terms that will indemnify Seller against all loss and additional expense, including, but not limited to demurrage, handling, storage, and insurance charges.

3.2 Unless otherwise stated in writing delivery shall be deemed to take place upon the occurrence of the first in time of the following, namely (a) the physical delivery of Products to the Buyer at the Seller's works; (b) the physical delivery of Products to the Buyer's carrier or agent for the purpose of transmission to the

Buyer or his nominee; (c) the physical delivery of Products to the Buyer's place of business or such other place as he may direct, its carrier or agent, the Buyer being responsible for unloading.

3.3 Signature of the Seller's delivery note by any employee, representative or agent of the Buyer shall be conclusive proof of delivery.

3.4 Where the contract provides for delivery by the Seller, its carrier or agent, any claims for non-delivery must be made in writing to the Seller within fifteen (15) days of receipt of invoice or advice note whichever is the earlier.

3.5 Where the contract provides for delivery by the Seller, its carrier or agent, any claims in respect of Products damaged in transit or shortages in delivery must be made in writing to the Seller within seven (5) days of delivery, shortages in delivery shall not give rise to a right to reject the Products delivered.

3.6 The Seller shall be entitled to make partial deliveries or deliveries by installments and all the provisions of these terms shall apply to such deliveries.

4 Payment Terms

4.1 Payment is due thirty (30) days from the date of invoice. All invoices are payable in US currency.

4.2 If Buyer is delinquent in its payment obligations for forty five (45) days or more, Seller may upon written notice to Buyer stop work and withhold future shipments until all delinquent amounts and late interest, if any, are paid.

4.3 Invoices unpaid and past due will be subject to a service charge on the unpaid balance at an interest rate equal to the lesser of two percent (2%) per month or the maximum allowable interest rate under applicable law, and Buyer shall be responsible and liable for all expenses incurred by Seller.

4.4 Buyer will not set off or recoup invoiced amounts or any portion thereof against sums that are due or may become due from Seller.

5 Title and Risk

5.1 The Product shall remain the property of Seller until full payment of the price has been effected.

5.2 Buyer shall, at the request of Seller, take any measures necessary to protect Seller's title to the Product.

5.3 The retention of title shall not affect the passing of risk in accordance with the respective applicable INCOTERM.

6 Returns

6.1 Products received by Buyer cannot be returned without Seller's prior consent.

6.2 Seller reserves the right to charge a restocking charge of an amount no less than twenty percent (20%) of the invoice value of Product on all returns, except in the event of an error on Seller's part.

6.3 Items ordered by Seller for special orders cannot be returned except under exceptional circumstances and in such cases, only subject to full agreement with Seller's supplier(s).

6.4 Products 'incorrectly ordered' or 'surplus to requirements' can only be returned within fourteen (14) days from date of shipment, and all returns conditions listed under this section apply to returned Products.

6.5 Products qualifying for return are subject to review for marketability (quantities in question in relationship to historical stock movement) before issuance of a Return Material Authorization (RMA) number.

6.6 All Product returns must be accompanied by a valid Return Material Authorization (RMA) number. RMA numbers may be obtained from the Seller. When requesting a RMA, the original purchase order number and date of purchase must be provided.

6.7 All Product returns must be received within thirty (30) days of the RMA issuance. 6.8 All Product returns must be shipped freight prepaid. No collect shipments will be accepted by Seller.

6.9 All Products must be received within one (1) year of original sale date.

6.10 Products for credit consideration should be returned in original packaging to Seller's originating location. All returns are subject to inspection upon receipt. No credit will be issued until returned Product has been inspected, accepted, and processed. 6.11 Buyer will be contacted if quantity differences and/or non-acceptable Product are found during inspection. Any credit issued will reflect only quantities actually received and accepted by Seller.

6.12 Disposition (return to Buyer or scrap) of returned Product not accepted back by Seller must be provided by Buyer within fourteen (14) days, otherwise it will be subject to disposal.

7. Warranty

7.1 "Non-conformance" means failure to comply with warranty, as defined below, within the Warranty Period.

7.2 Normal wear and tear, regular overhaul, and periodic maintenance do not constitute non-conformance.

7.3 Seller warrants that its Products shall conform to the description of such Products as provided to Buyer by Seller through Seller's Product literature. This warranty is exclusive, and Seller makes no other warranty, express or implied, including any implied warranty or merchantability or fitness for any particular purpose or course of dealing or usage of trade, which are hereby disclaimed. Seller's warranties made in connection of a sale shall not be effective if Seller has determined, in its sole discretion, that Buyer has misused the Products in a manner depicting non-conformance, has failed to use the Products in accordance with industry standards and practices, or has failed to use the Products in accordance with instructions, if any, furnished by Seller. Seller does not warrant any Products obtained through an unauthorized Distributor, Dealer, or Agent.

7.4 The "Warranty Period" for all Products listed in Seller's Product literature shall carry a five (5) year warranty within the United States. The 5 year warranty period is unconditional for the first two (2) years from the date of production of Products. After the first 2 years from the date of sale, the warranty shall be conditional and the warranty coverage shall not apply to damage to Products caused by factors that constitute non-conformance beyond the control of Seller. The period shall begin on the later of (a) the date on which the Product first enters a retail distribution/sales channel, or (b) the date of delivery to the end user provided Buyer presents the end user's retail invoice demonstrating such date of delivery. Products that are listed in this Product Guide as carrying a 2-year warranty to a location in the United States or Canada shall carry a 2-year warranty. The 2-year warranty is conditional and the warranty coverage shall not apply to damage to Products caused by ordinary wear and tear, negligence or improper use by Client, or other causes beyond the control of the Seller. Product specific terms of warranty with regard to warranty period or conditions of warranty may apply to certain specified Products as stated in the documentation for those Products.

7.5 Seller warrants to Buyer that at the time of shipment and for the Warranty Period: (a) the Product will be free from defects in workmanship and materials, and (b) the Product will comply with the drawings, specifications, and operating conditions as set forth in Seller's instructions, manuals, or specifications.

7.6 This Warranty does not apply to prototype, development, and pre-production Products. All prototype, development, and

pre-production Products are accepted by Buyer on an "AS IS" basis with no warranties whatsoever. Furthermore, Seller shall not be responsible for any non-conformance if the Product has been exposed or subjected to any: (a) use of the Product other than specified in applicable Seller's instructions, manuals, or specifications; or (b) operation of Product outside of operating limits and parameters; or (c) maintenance, repair, overhaul, installation, storage, operation or use, which is improper or not in accordance with Seller's instructions, manuals, or specifications; or (d) alteration, modification, including by integration of Products into or with Buyer's equipment, or (e) accident, contamination, foreign object damage, abuse, neglect or negligence after shipment to Buyer; or (f) use of counterfeit or replacement parts that are not manufactured or approved by Seller for use in Seller's manufactured Products; or (g) damage caused by failure of any hardware or software not supplied by Seller or a Seller supplied Product not under warranty. 7.7 Buyer must notify Seller of any claimed non-conformance in writing by returning a Returned Material Authorization Form ("RMA Form") to Seller.

7.8 Prior to returning any Products under warranty, Buyer must obtain an RMA number from Seller. The RMA Form must be received by Seller within ninety (90) days of Buyer's discovery of any claimed non-conformance and must contain a detailed description of any claimed non-conformance or Buyer will be barred from any remedy under the Warranty.

7.9 Upon Seller's receipt of Buyer's completed RMA Form, Seller will provide Buyer with a Returned Material Authorization Number ("RMA#"). Buyer must await its receipt of the RMA# before returning any Product to Seller.

7.10 Seller will return, at Buyer's expense, any Product not properly identified or associated with an RMA#. When Seller requires the examination of claimed non-conforming Product, Seller will notify Buyer as to the place of return and will await receipt of the claimed non-conforming Product before further processing the warranty claim.

7.11 Buyer will ship the Product by normal ground shipment and bear the cost of shipment and risk of loss or damage to Products while in transit to Seller.

7.12 If Seller ultimately determines that the failed part is covered under Warranty, Shipper will reimburse Buyer for the cost of ground shipment for the Product(s) found to be in non-conformance.

7.13 If Seller reasonably determines after analysis of the returned Product that a non-conformance does not exist, then Buyer will pay all expenses related to the improper return including, but not limited to, analysis and shipping charges.

7.14 Any claimed non-conforming Product must be received by Seller within thirty (30) days of issuance of a notice to return Product. 7.15 If Seller determines that a Product does not conform to Warranty, Seller may elect, in its sole discretion, to repair, replace, or exchange the Product, or credit the original purchase price. In addition, Seller will credit Buyer for standard labor and handling costs (to be agreed case by case) per applicable Product.

7.16 Repair, replacement, exchange, or credit of the original purchase price and standard labor and handling costs are the exclusive remedies under Seller's Warranty. All Products repaired, replaced or exchanged are warranted for a period equal to the greater of: (a) the remainder of the original 5 year Warranty Period or 2 year Warranty that was applicable to the repaired, replaced or exchanged Products, or six (6) months, effective from the date the repaired, replaced or exchanged Products are shipped by Seller.

8 Limitation of Liability

8.1 In no event will Seller be liable for any incidental damages, consequential damages, special damages, punitive damages, statutory damages, indirect damages, loss of shipment, loss of products, loss of profits, loss of revenues, loss of use or damage to brand name, even if informed of the possibility of such damages. Seller's liability for damages arising out of or related to this agreement shall in no case exceed in the aggregate a sum equal to twice the amount actually paid to Seller for the products from which the claim arose. Further, if buyer requires Seller to use a particular supplier or suppliers, then Seller shall have no liability for the supplier(s) performance, nor for any damages caused directly or indirectly by Seller's product to the extent resulting from incorporation of such supplier(s) product. To the extent permitted by applicable law, these limitations and exclusions will apply regardless of whether liability arises from breach of contract, warranty, tort (including but not limited to negligence), by operation of law, or otherwise. Nothing herein, however, is intended to disclaim Seller's liability for personal injury or death caused by defective products to the extent such liability is mandated by law.

9 Place of Jurisdiction and Applicable Law

9.1 The exclusive place of jurisdiction for all disputes arising from these Terms between the parties shall be governed by the laws of the State of Delaware and the parties shall be governed exclusively by the formal and material laws of the Federal and state courts located in the State of Delaware without reference to its conflict of law provisions. All disputes arising hereunder or in connection with Products shall be subject to the exclusive jurisdiction of the courts of the State of Delaware, to which the parties hereby submit themselves.