

CVS Valve Series

Characterized Valve for Steam Applications

Technical Document



Subject to change. © Siral USA LLC.

Ver. 2.00-B

CVS Technical Document

Contents

Overview	2	V-NBV24 Actuator Series	5
Stability and Control	2	V-NDV24 Actuator Series	6
Design	2	V-FBV24 Actuator Series	7
Ball valve Technology	2	V-FDV24 Actuator Series	8
Snapshot	2	Dimensions	9
Nomenclature	4	Non-Spring Return	9
Valve-Actuator Combinations	4	Spring-Return (Fail-Safe)	9
		Terms and Conditions	10 - 12

Overview

The Siral steam characterized control valve is the intelligent solution for low pressure steam. The CVS's compact design, zero leakage and metal characterizing disc combines durability, control and efficiency. A better and more efficient alternative to a globe valve for 1/2" to 1" size applications.

Siral ball valve technology uses lower torque actuators than globe valves, hence the CVS is a more cost optimized solution. Offering an Equal percentage flow characteristic gives the CVS better control than globe valves even at very low flows. The Siral CVS is bubble tight valve unlike a comparable globe valve. This eliminates energy loss and discomfort cost by internal leakage. Its

The Siral CVS is an electronically actuated characterized control ball valve. Control signal options include on/off, floating point or modulating (proportional) and are used to determine the final positioning of the ball rotation angle which determines the amount of flow through the valve.

Stability and Control

- The valve's equal percentage characteristic provides a linear change in thermal output based on the valve's opening angle that is controlled by the actuator's input signal.
- With its built-in stainless-steel ball and brass disc, the CVS is designed to provide durability and flow accuracy that are lacked in other plastic disks lack.
- The brushless DC motor technology has longer life due to its low friction design.
- The valve is designed with efficiency in mind. It incorporates a leak-free auto-cleaning ball assembly. Its thermal barrier flange reduces heat-transfer to the actuator extending its life.
- Internal leakage in a valve causes energy waste. Most 3-way valves in the industry usually have some level of internal leakage even when new. With our unique valve design both our 2-way and 3-way valves are bubble tight with zero leakage through all ports.
- Brushless motor technology improves efficiency due to reduced heat output compared to conventional motors.



Design

- Stainless steel ball and stem – Maximum corrosion resistance
- Nickel plated brass body –Reduces stress concentration
- Engineered thermal barrier
- Brushless DC Motor technology

Ball valve Technology

- Self cleaning ball – Eliminates blockage and leakage caused by damaged surfaces
- Blowout proof stem – Safety during system pressure spikes
- Floating seat design – Stable torque through life
- Zero Internal leakage – Stops energy waste caused by leakage.

Snapshot

- Flow patterns: 2-Way
- Size range: 1/2 to 1"
- C_v range: 0.3 to 30
- Control: On/Off, Floating Point, Modulating (2-10VDC)

Nomenclature

Valve			Actuator				
B2	15	S	+V-NBV	24	M	-T	-S
Flow Style	DN Size	Steam	Non-Spring Return	Power Supply	Control Signal	Electric Connection	Auxiliary
B2..S=2-Way	03 - 98	S = Steam	V-NBV	24 VAC	M = Modulate	-T = Terminal	-S = Switch
			V-NDV	120 VAC	F = Float	Blank= 3 ft. *	Blank= No Switch
				240 VAC	= On/Off		

Fail-Safe
V-FBV
V-FDV

* Includes 1/2" Conduit on on all actuators except V-NB Series.

**Switch option available for V-ND, V-NF and V-FF Series only

Normal Position (Non-Fail-Safe)
NC= Normally Closed
NO= Normally Open

Normal Position (Fail-Safe)
NC/FC= Normally Closed, Fail Closed
NO/FC= Normally Open, Fail Closed
NC/FO= Normally Closed, Fail Open
NC/FC= Normally Closed, Fail Closed

Valve-Actuator Combinations

Valve				Actuator			
Inches	DN	C _v	2-Way	Non-Spring Return		Fail-Safe	
1/2	15	0.3	B203S	V-NBV - Series	V-NDV - Series	V-FBV - Series	V-FDV - Series
		0.46	B205S				
		0.8	B207S				
		1.2	B209S				
		1.9	B211S				
		3	B213S				
3/4	20	4.7	B215S				
		1.9	B233S				
		2.9	B236S				
		4.7	B239S				
		7.4	B241S				
		10	B243S				
1	25	14	B245S				
		7.4	B251S				
		10	B253S				
		19	B255S				
		30	B257S				

CVS Valve Series

Steam Characterized Ball Valve (Stainless-Steel Ball and Stem)

2-Way

Sizes: 1/2" to 1" NPT



Specifications		
Sizes [DN]		1/2" to 1" [15 to 25]
C _v	Range	0.3 to 30
	Type	Low pressure steam
Media	Temperature	0°F to 250°F [-18°C to 120°C]
	Body	600 psi
Pressure	Close-Off	200 psi
	Differential (ΔP)	15 psid
Leakage	A-AB Port	0%
	Rating	according to EN 12266-1:2003
Materials	Body	Nickle-Plated Forged Brass
	Ball and Stem	316 Stainless-Steel
	Seats	PTFE
	Characterized Disc	Brass
	Stem O-Rings	EPDM
Flow	Curve	Equal %
	Pattern	2-Way, 3-Way mixing, 3-Way diverting
	Control Angle	75°
Rangeability		100 : 1
Valve	Connection	Female NPT

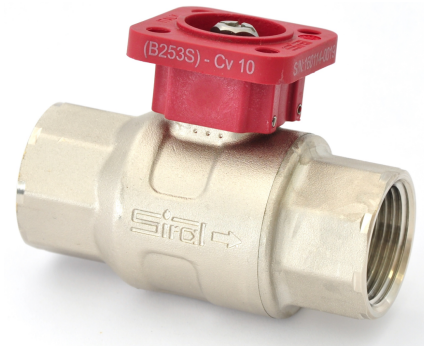

Application

The CVS series of steam characterized ball valves provide accurate flow control in low pressure steam HVAC applications. Its equal percentage flow characteristic curve is typically used in fan coil units, unit ventilators, and steam coils.

Operation

The Siral CVS is an electronically actuated characterized control ball valve. Control signal options include on/off, floating point or modulating (proportional) and are used to determine the final positioning of the ball rotation angle which determines the amount of flow through the valve.

Flow Pattern (2-Way)

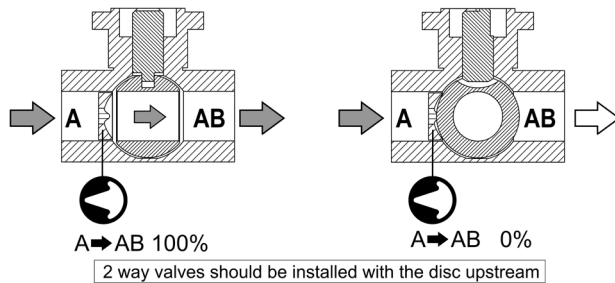

INSTALLATION

Valve cannot be mounted vertically. If mounted horizontally valve must be 0° to 45° off the horizontal line across the center of the pipe. Do not install with actuator below pipe.

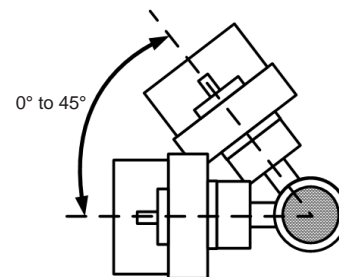

PIPING

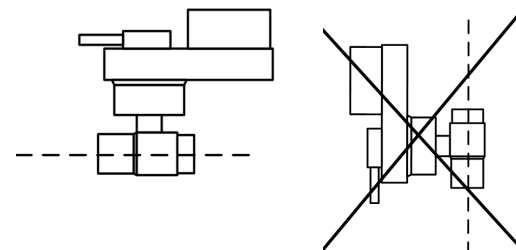
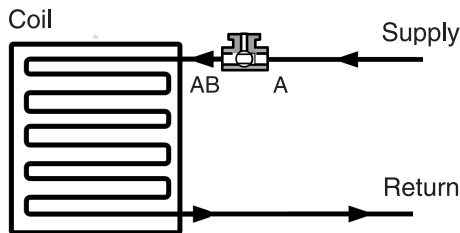

V-NBV24 Actuator Series

On/Off, Floating (3-Point), Modulating
Non-Spring Return



Specifications		(F) Floating, On/Off †	(M) Modulating ††
Control	Signal	On/Off, Floating (3-Point)	2-10 VDC, 4-20mA
	Input Impedance	0.36 kΩ	100 kΩ
Power	Voltage AC	24 VAC/60 Hz ± 20%	
	Voltage DC	N/A	24 VDC -10% +20%
	Consumption	1 W	0.5 W
	Transformer	1 VA (Class 2)	
	Connection	Terminals, Cable: 3 Ft.(1 m), 10 Ft. (3 m)	
Operation	Runtime (Motor)	90 seconds	
	Manual Override	Push-down knob	
	Rotation Angle	90°	
	Position Indicator	Manual Knob	
	Noise	35 dBA	
Housing	Protection	NEMA 1 / IP40	
	Rating	UL94-5V (B)	
Temp.	Ambient	-22°F to 122°F (-30°C to 50°C)	
	Storage	-40°F to 176°F (-40°C to 80°C)	
	Humidity	5 to 95% non-condensing	
Agency Listing	<ul style="list-style-type: none"> • cULus UL 60730-1A/-2-14, • CAN/CSA E60730-1:02, • CE according to 2004/108/EC and 2006/95/EC for line voltage 		

† Rated impulse voltage 330V, Control pollution degree 2, Type of action 1
 †† Rated impulse voltage 500V, Control pollution degree 2, Type of action 1

Floating, On/Off: **V-NBV24F**
 Modulating: **V-NBV24M**



WARNING



Connect the Actuator Common to the Controller Hot connection. Actuator must be installed by licensed or electrically trained technician. Failure to follow electrical safety precaution when working with live electrical connection could result in injury or death.

Wiring

Modulating Wiring

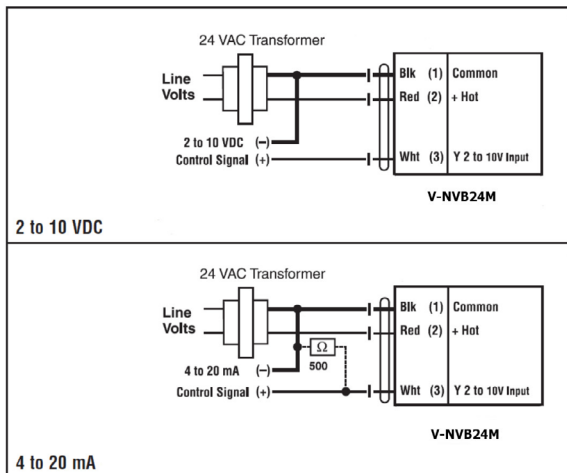

Floating and On/Off Wiring

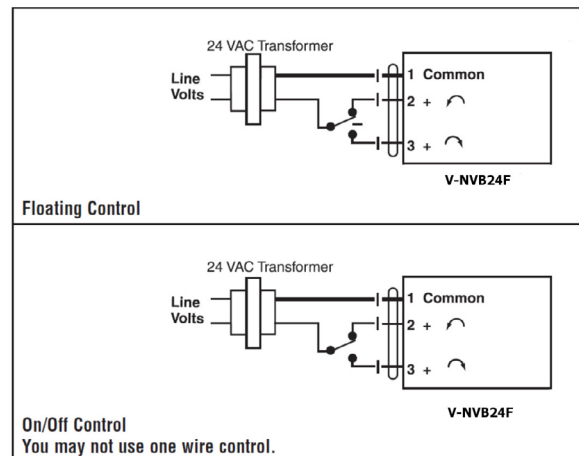

On/Off Control
 You may not use one wire control.
 Direct/Reverse acting switch is under wiring cover.
 R = CW with decrease in signal
 L = CCW with decrease in signal
 No feedback

V-NDV24 Actuator Series

On/Off, Floating (3-Point), Modulating
Non-Spring Return



Specifications		(F) Floating, On/Off †	(M) Modulating †
Control	Signal	On/Off, Floating (3-Point)	2-10 VDC, 4-20mA
	Input Impedance	600 Ω	100 kΩ
	Feedback Signal		1-10 VDC
Power	Voltage AC	24 VAC 50/60 Hz ± 20%	
	Voltage DC	24 VDC ±10%	
	Overload Protection	Electronic overload protection	
	Consumption Running	1.5 W	1.5 W
	Consumption Holding	0.2 W	0.4 W
	Transformer	2 VA (Class 2)	3 VA (Class 2)
	Connection	Terminals, Plenum rated cable 18 GA: 3 Ft.(1 m), 10 Ft. (3 m)	
Operation	Runtime (Motor)	90 seconds	
	Manual Override	Push-button	
	Rotation Angle	90°, adjustable using Screwed tabs	
	Rotation Direction	Direction Switch ↺ ↻	
	Position Indicator	Manual Knob	
	Noise	35 dBA	
Housing	Protection	NEMA 1 / IP40	
	Rating	UL94-5V (B)	
Temp.	Ambient	-22°F to 122°F (-30°C to 50°C)	
	Storage	-40°F to 176°F (-40°C to 80°C)	
	Humidity	5 to 95% non-condensing	
Agency Listing	<ul style="list-style-type: none"> • cULus UL 60730-1A/-2-14, • CAN/CSA E60730-1:02, • CE according to 2004/108/EC and 2006/95/EC for line voltage 		

† Rated impulse voltage 800V, Control pollution degree 3, Type of action 1

Floating, On/Off: V-NDV24F
Modulating: V-NDV24M



WARNING



Connect the Actuator Common to the Controller Hot connection. Actuator must be installed by licensed or electrically trained technician. Failure to follow electrical safety precaution when working with live electrical connection could result in injury or death.

Floating and On/Off Wiring

Meets cULus or UL and CSA requirements without the need of an electrical ground connection.

Wiring

Modulating Wiring

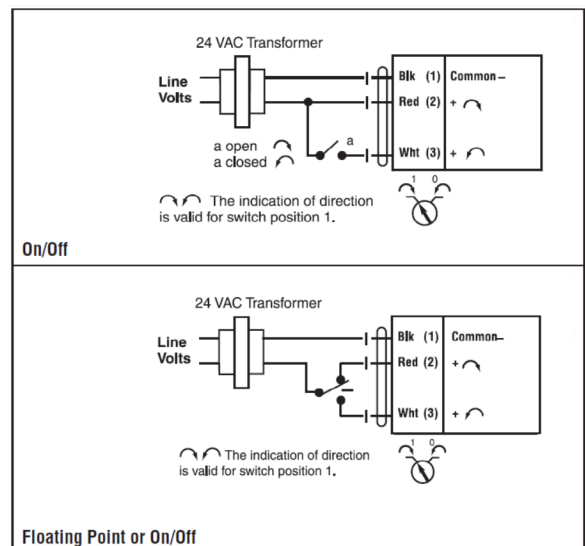
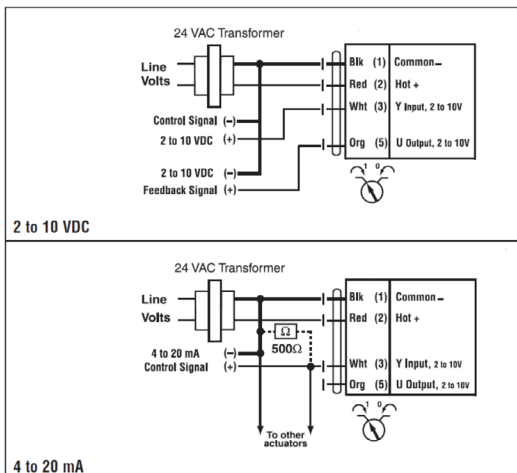

V-FBV24 Actuator Series

On/Off, Floating (3-Point), Modulating
Spring-Return (Fail-Safe)



Specifications		On/Off†	(F) Floating†	(M) Modulating†
Control	Signal	On/Off	Floating (3-Point)	2-10 VDC, 4-20mA
	Input Impedance		1000 Ω	100 kΩ
Power	Voltage AC	24 VAC 50/60 Hz ± 20%		
	Voltage DC	24 VDC ±10%		24 VDC ±10%
	Overload Protection	Electronic overload protection		
	Consumption Running	2.5 W		
	Consumption Holding	1.3 W	1 W	
	Transformer	5 VA (Class 2)	4 VA (Class 2)	
	Connection	<ul style="list-style-type: none"> Terminals, Plenum rated cable 18 GA: 3 Ft.(1 m), 10 Ft. (3 m) 		
Operation	Runtime (Motor)	95 seconds		
	Runtime (Spring)	<75 sec @ -22°F to 122°F [-20°C to 50°C]	<25 sec @ -4°F to 122°F [-20°C to 50°C]	<60 sec @ -22°F [-30°C]
	Manual Override	Push-button		
	Rotation Angle	95°, adjustable using Screwed tabs		
	Rotation Direction (Motor)	Direction Switch ↻ ↻		
	Rotation Direction (Spring)	Reversible with CW/CCW mounting		
	Position Indicator	Visual		
	Noise Motor	<40 dBA	<35 dBA	
	Noise Spring	<40 dBA	<62 dBA	
	Protection	NEMA 2 / IP42		
Housing	Rating	UL94-5VA		
	Ambient	-22°F to 122°F (-30°C to 50°C)		
Temp.	Storage	-40°F to 176°F (-40°C to 80°C)		
	Humidity	5 to 95% non-condensing		
Agency Listing	<ul style="list-style-type: none"> cULus UL 60730-1A/-2-14, CAN/CSA E60730-1:02, CE according to 2004/108/EC and 2006/95/EC for line voltage 			

† Rated impulse voltage 800V, Control pollution degree 3, Type of action 1.AA

On/Off: V-FBV24
Floating: V-FBV24F
Modulating: V-FBV24M

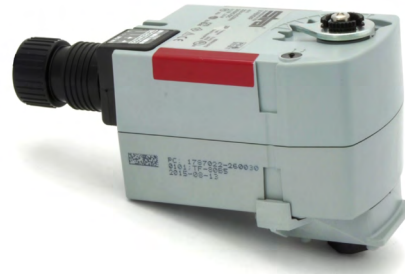

WARNING



Connect the Actuator Common to the Controller Hot connection. Actuator must be installed by licensed or electrically trained technician. Failure to follow electrical safety precaution when working with live electrical connection could result in injury or death.

Floating Wiring

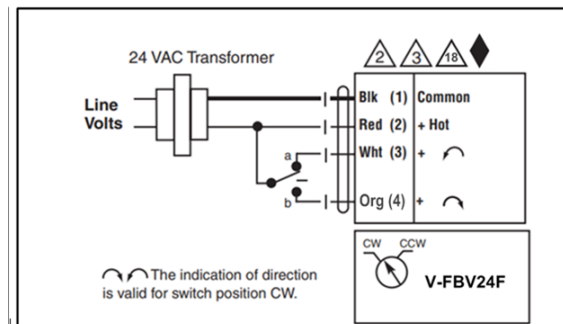

Modulating Wiring

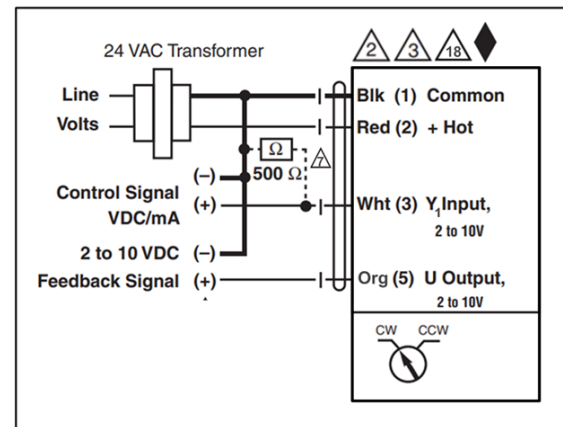

Wiring

On/Off Wiring

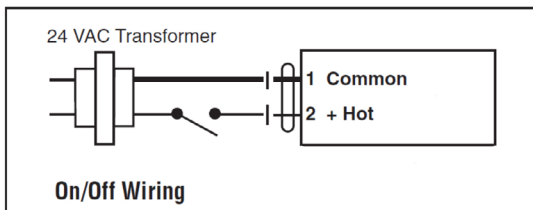

Actuators may also be powered by 24 VDC.

V-FDV24 Actuator Series

On/Off, Floating (3-Point), Modulating
Spring-Return (Fail-Safe)



Specifications		On/Off†	(F) Floating†	(M) Modulating†
Control	Signal	On/Off	Floating (3-Point)	2-10 VDC, 4-20mA
	Input Impedance		1000 Ω	100 kΩ
Power	Voltage AC	24 VAC 50/60 Hz ± 20%		
	Voltage DC	24 VDC ±10%		24 VDC ±10%
	Overload Protection	Electronic overload protection		
	Consumption Running	2.5 W		
	Consumption Holding	1.3 W	1 W	
	Transformer	5 VA (Class 2)	4 VA (Class 2)	
	Connection	<ul style="list-style-type: none"> Terminals, Plenum rated cable 18 GA: 3 Ft.(1 m), 10 Ft. (3 m) 		
Runtime (Motor)	40 to 75 seconds			
Runtime (Spring)	<75 sec @ -22°F to 122°F [-20°C to 50°C]	<25 sec @ -4°F to 122°F [-20°C to 50°C]	<60 sec @ -22°F [-30°C]	
Manual Override	Push-button			
Rotation Angle	95°, adjustable using Screwed tabs			
Operation	Rotation Direction (Motor)	Direction Switch		
	Rotation Direction (Spring)	Reversible with CW/CCW mounting		
	Position Indicator	Visual		
	Noise Motor	<40 dBA	<30 dBA	
Housing	Protection	NEMA 2 / IP42		
	Rating	UL94-5VA		
Temp.	Ambient	-22°F to 122°F (-30°C to 50°C)		
	Storage	-40°F to 176°F (-40°C to 80°C)		
	Humidity	5 to 95% non-condensing		
Agency Listing	<ul style="list-style-type: none"> cULus UL 60730-1A/-2-14, CAN/CSA E60730-1:02, 			

† Rated impulse voltage 800V, Control pollution degree 3, Type of action 1.AA

Wiring

On/Off Wiring

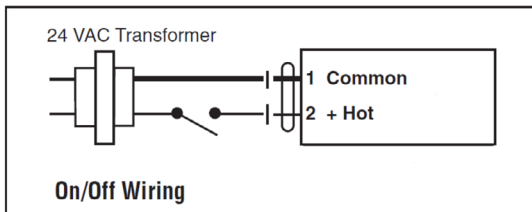

Actuators may also be powered by 24 VDC.

On/Off: V-FDV24
Floating: V-FDV24F
Modulating: V-FDV24M



WARNING

Connect the Actuator Common to the Controller Hot connection. Actuator must be installed by licensed or electrically trained technician. Failure to follow electrical safety precaution when working with live electrical connection could result in injury or death.

Floating Wiring

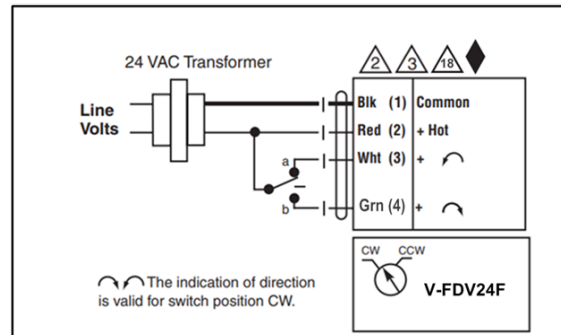

Modulating Wiring

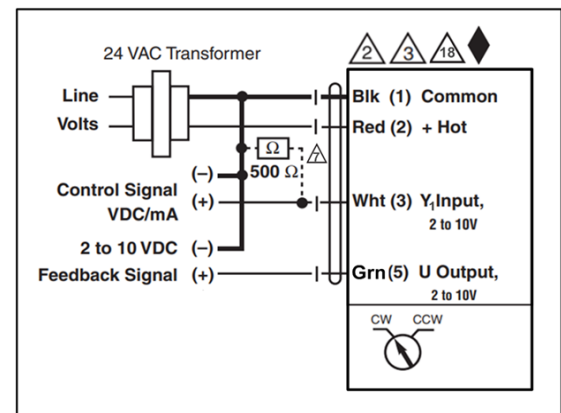

Dimensions

(Inches [mm])



Non-Spring Return

Actuator (V-NBV24) with 2-Way CVS

Valve	Size	DN	A	B	C	C	E
B203S-B225S	1/2"	15	3.72 [94.5]	2.66 [67.5]	4.85 [123.2]	4.25 [108]	0.89 [22.5]
B233S-B243S	3/4"	20	3.92 [99.5]	3.01 [76.5]	5.18 [131.5]	4.41 [112]	0.89 [22.5]

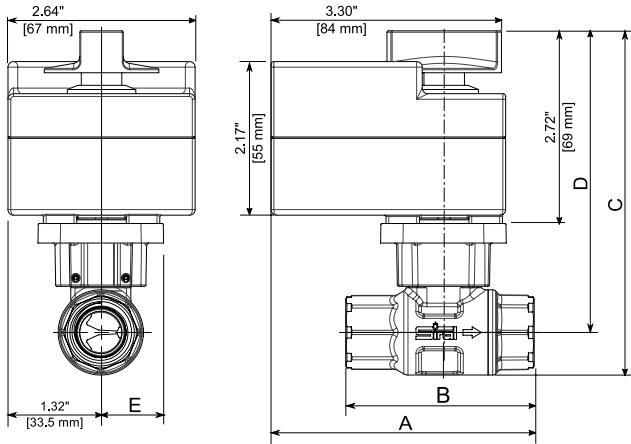

Actuator (V-NDV24) with 2-Way CVS

Valve	Size	DN	A	B	C	C	E
B233S-B243S	3/4"	20	6.8 [172.5]	3.01 [76.5]	5.69 [144.5]	4.92 [125]	0.89 [22.5]
B251S-B257S	1"	25	7.2 [183]	3.78 [96]	6.04 [153.5]	5.1 [129.5]	0.94 [24]

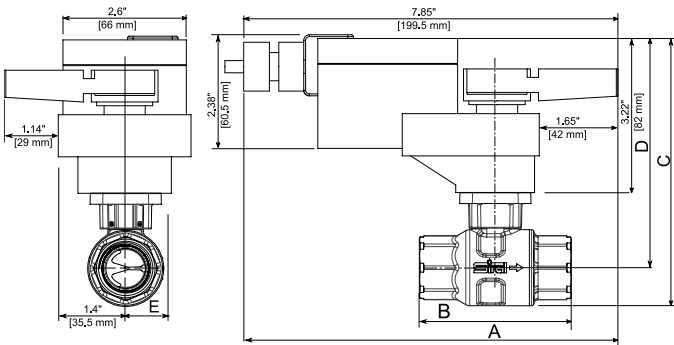

Spring-Return (Fail-Safe)

Actuator (V-FBV24) with 2-Way CVS

Valve	Size	DN	A	B	C	C	E
B203S-B225S	1/2"	15	6.81 [173]	2.66 [67.5]	5.32 [135.2]	4.72 [120]	0.89 [22.5]
B233S-B243S	3/4"	20	7.01 [178]	3.01 [76.5]	5.65 [143.5]	4.88 [124]	0.89 [22.5]

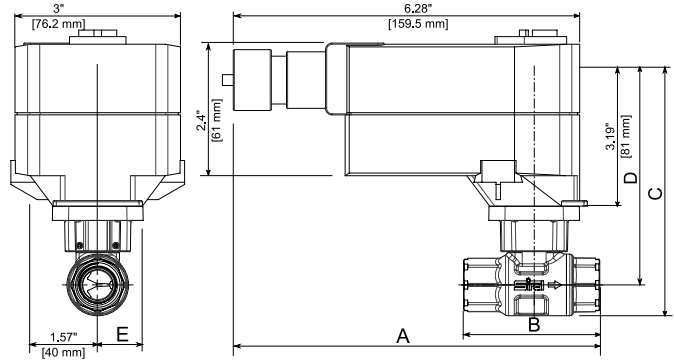

Actuator (V-FDV24) with 2-Way CVS

Valve	Size	DN	A	B	C	C	E
B233S-B243S	3/4"	20	8.13 [206.5]	3.01 [76.5]	5.92 [150.5]	5.16 [131]	0.89 [22.5]
B251S-B257S	1"	25	8.54 [217]	3.78 [96]	6.28 [159.5]	5.33 [135.5]	0.94 [24]

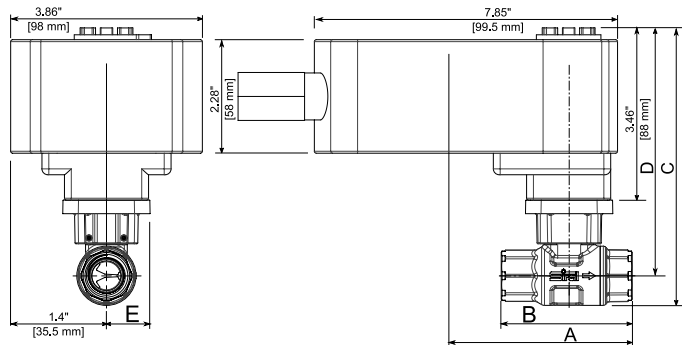

Ver. 2.00-B Subject to change. © Siral USA LLC.

CVS Technical Document

Terms and Conditions

1 Applicable Terms and Conditions of Sale

1.1 These Terms and Conditions of Sale ("Terms") establish the rights, obligations and remedies of "Seller" and "Buyer" which apply to any order issued by Buyer for the purchase of products described in its product guide, catalogs, analytical data and other literature ("Products"). As used herein, "Seller" shall mean Siral, as applicable, and "Buyer" shall mean any party, individual or business entity, who contracts to purchase products from Seller. These Terms shall prevail over any conflicting terms or conditions Buyer may submit at any time, unless otherwise specifically agreed in writing by both Buyer and Seller.

2 Prices

2.1 All prices are in US currency unless otherwise clearly specified in an accepted agreement.

2.2 Prices on products are exclusive of all sales, excise and other taxes, and exclusive of freight, handling and storage charges, any or all of which, as applicable, will be added as separate charges to be paid by the Buyer or otherwise charged as indicated in these Terms. If Seller is required to impose, levy, collect, withhold or assess any such taxes, duties or charges on any transactions, then in addition to the purchase price, Seller will invoice Buyer for such taxes, duties, and charges unless at the time of order placement Buyer provides Seller with an exemption certificate or other documentation sufficient to verify exemption from such taxes, duties or charges.

2.3 Seller reserves the right to change its prices if from the time of quotation (a) raw material and/or component prices have changed; or (b) actual volume is less than forecast volume; or (c) there is any significant change in economic circumstance; or modifications requested by Buyer give rise to additional costs.

2.4 Price quotations are effective for thirty (30) days subsequent to the date at which the quotation is given. Unless otherwise agreed by Seller in writing, price quotations provided by Seller are not intended as and shall not be construed as constituting an offer to Buyer. Any prices provided by Seller is subject to, and shall not become binding upon Seller until, (a) actual receipt by Seller of Buyer's written order based on all the terms and conditions stated herein, without qualification, within thirty (30) days after the date of the price quotation, and (b) Seller's written acceptance of such order.

2.5 Unless otherwise specified by Seller, all prices are F.O.B. Point of Origin from which shipment is made and payment terms will be net thirty (30) days from date of invoice.

2.6 Buyer will be charged a handling fee of US \$20 for all orders with a net value of less than US \$300. Freight, expedited fees or any other shipping charges shall be paid by Buyer and are in addition to the price of goods within the order including Buyer's minimum order charge.

3 Delivery

3.1 All delivery dates are approximate, and Seller shall not be responsible for any damages or losses of any kind resulting from any delay. Unless otherwise agreed by Seller, Seller may exercise its judgment in choosing the carrier and means of delivery. No deferment of shipment at Buyer's request beyond the respective dates indicated in Buyer's orders shall be made except on terms that will indemnify Seller against all loss and additional expense, including, but not limited to demurrage, handling, storage, and insurance charges.

3.2 Unless otherwise stated in writing delivery shall be deemed to take place upon the occurrence of the first in time of the following, namely (a) the physical delivery of Products to the Buyer at the Seller's works; (b) the physical delivery of Products to the Buyer's carrier or agent for the purpose of transmission to the

Buyer or his nominee; (c) the physical delivery of Products to the Buyer's place of business or such other place as he may direct, its carrier or agent, the Buyer being responsible for unloading.

3.3 Signature of the Seller's delivery note by any employee, representative or agent of the Buyer shall be conclusive proof of delivery.

3.4 Where the contract provides for delivery by the Seller, its carrier or agent, any claims for non-delivery must be made in writing to the Seller within fifteen (15) days of receipt of invoice or advice note whichever is the earlier.

3.5 Where the contract provides for delivery by the Seller, its carrier or agent, any claims in respect of Products damaged in transit or shortages in delivery must be made in writing to the Seller within seven (7) days of delivery, shortages in delivery shall not give rise to a right to reject the Products delivered.

3.6 The Seller shall be entitled to make partial deliveries or deliveries by installments and all the provisions of these terms shall apply to such deliveries.

4 Payment Terms

4.1 Payment is due thirty (30) days from the date of invoice. All invoices are payable in US currency.

4.2 If Buyer is delinquent in its payment obligations for forty five (45) days or more, Seller may upon written notice to Buyer stop work and withhold future shipments until all delinquent amounts and late interest, if any, are paid.

4.3 Invoices unpaid and past due will be subject to a service charge on the unpaid balance at an interest rate equal to the lesser of two percent (2%) per month or the maximum allowable interest rate under applicable law, and Buyer shall be responsible and liable for all expenses incurred by Seller.

4.4 Buyer will not set off or recoup invoiced amounts or any portion thereof against sums that are due or may become due from Seller.

5 Title and Risk

5.1 The Product shall remain the property of Seller until full payment of the price has been effected.

5.2 Buyer shall, at the request of Seller, take any measures necessary to protect Seller's title to the Product.

5.3 The retention of title shall not affect the passing of risk in accordance with the respective applicable INCOTERM.

6 Returns

6.1 Products received by Buyer cannot be returned without Seller's prior consent.

6.2 Seller reserves the right to charge a restocking charge of an amount no less than twenty percent (20%) of the invoice value of Product on all returns, except in the event of an error on Seller's part.

6.3 Items ordered by Seller for special orders cannot be returned except under exceptional circumstances and in such cases, only subject to full agreement with Seller's supplier(s).

6.4 Products 'incorrectly ordered' or 'surplus to requirements' can only be returned within fourteen (14) days from date of shipment, and all returns conditions listed under this section apply to returned Products.

6.5 Products qualifying for return are subject to review for marketability (quantities in question in relationship to historical stock movement) before issuance of a Return Material Authorization (RMA) number.

6.6 All Product returns must be accompanied by a valid Return Material Authorization (RMA) number. RMA numbers may be obtained from the Seller. When requesting a RMA, the original purchase order number and date of purchase must be provided.

6.7 All Product returns must be received within thirty (30) days of the RMA issuance.

6.8 All Product returns must be shipped freight prepaid. No collect shipments will be accepted by Seller.

6.9 All Products must be received within one (1) year of original sale date.

6.10 Products for credit consideration should be returned in original packaging to Seller's originating location. All returns are subject to inspection upon receipt. No credit will be issued until returned Product has been inspected, accepted, and processed. 6.11 Buyer will be contacted if quantity differences and/or non-acceptable Product are found during inspection. Any credit issued will reflect only quantities actually received and accepted by Seller.

6.12 Disposition (return to Buyer or scrap) of returned Product not accepted back by Seller must be provided by Buyer within fourteen (14) days, otherwise it will be subject to disposal.

7. Warranty

7.1 "Non-conformance" means failure to comply with warranty, as defined below, within the Warranty Period.

7.2 Normal wear and tear, regular overhaul, and periodic maintenance do not constitute non-conformance.

7.3 Seller warrants that its Products shall conform to the description of such Products as provided to Buyer by Seller through Seller's Product literature. This warranty is exclusive, and Seller makes no other warranty, express or implied, including any implied warranty or merchantability or fitness for any particular purpose or course of dealing or usage of trade, which are hereby disclaimed. Seller's warranties made in connection of a sale shall not be effective if Seller has determined, in its sole discretion, that Buyer has misused the Products in any manner depicting non-conformance, has failed to use the Products in accordance with industry standards and practices, or has failed to use the Products in accordance with instructions, if any, furnished by Seller. Seller does not warrant any Products obtained through an unauthorized Distributor, Dealer, or Agent.

7.4 The "Warranty Period" for all Products listed in Seller's Product literature shall carry a five (5) year warranty within the United States. The 5 year warranty period is unconditional for the first two (2) years from the date of production of Products. After the first 2 years from the date of sale, the warranty shall be conditional and the warranty coverage shall not apply to damage to Products caused by factors that constitute non-conformance beyond the control of Seller. The period shall begin on the later of (a) the date on which the Product first enters a retail distribution/sales channel, or (b) the date of delivery to the end user provided Buyer presents the end user's retail invoice demonstrating such date of delivery. Products that are listed in this Product Guide as carrying a 2-year warranty to a location in the United States or Canada shall carry a 2-year warranty. The 2-year warranty is conditional and the warranty coverage shall not apply to damage to Products caused by ordinary wear and tear, negligence or improper use by Client, or other causes beyond the control of the Seller. Product specific terms of warranty with regard to warranty period or conditions of warranty may apply to certain specified Products as stated in the documentation for those Products.

7.5 Seller warrants to Buyer that at the time of shipment and for the Warranty Period: (a) the Product will be free from defects in workmanship and materials, and (b) the Product will comply with the drawings, specifications, and operating conditions as set forth in Seller's instructions, manuals, or specifications.

7.6 This Warranty does not apply to prototype, development,

and pre-production Products. All prototype, development, and pre-production Products are accepted by Buyer on an "AS IS" basis with no warranties whatsoever. Furthermore, Seller shall not be responsible for any non-conformance if the Product has been exposed or subjected to any: (a) use of the Product other than specified in applicable Seller's instructions, manuals, or specifications; or (b) operation of Product outside of operating limits and parameters; or (c) maintenance, repair, overhaul, installation, storage, operation or use, which is improper or not in accordance with Seller's instructions, manuals, or specifications; or (d) alteration, modification, including by integration of Products into or with Buyer's equipment, or (e) accident, contamination, foreign object damage, abuse, neglect or negligence after shipment to Buyer; or (f) use of counterfeit or replacement parts that are not manufactured or approved by Seller for use in Seller's manufactured Products; or (g) damage caused by failure of any hardware or software not supplied by Seller or a Seller supplied Product not under warranty. 7.7 Buyer must notify Seller of any claimed non-conformance in writing by returning a Returned Material Authorization Form ("RMA Form") to Seller.

7.8 Prior to returning any Products under warranty, Buyer must obtain an RMA number from Seller. The RMA Form must be received by Seller within ninety (90) days of Buyer's discovery of any claimed non-conformance and must contain a detailed description of any claimed non-conformance or Buyer will be barred from any remedy under the Warranty.

7.9 Upon Seller's receipt of Buyer's completed RMA Form, Seller will provide Buyer with a Returned Material Authorization Number ("RMA#"). Buyer must await its receipt of the RMA# before returning any Product to Seller.

7.10 Seller will return, at Buyer's expense, any Product not properly identified or associated with an RMA#. When Seller requires the examination of claimed non-conforming Product, Seller will notify Buyer as to the place of return and will await receipt of the claimed non-conforming Product before further processing the warranty claim.

7.11 Buyer will ship the Product by normal ground shipment and bear the cost of shipment and risk of loss or damage to Products while in transit to Seller.

7.12 If Seller ultimately determines that the failed part is covered under Warranty, Shipper will reimburse Buyer for the cost of ground shipment for the Product(s) found to be in non-conformance.

7.13 If Seller reasonably determines after analysis of the returned Product that a non-conformance does not exist, then Buyer will pay all expenses related to the improper return including, but not limited to, analysis and shipping charges.

7.14 Any claimed non-conforming Product must be received by Seller within thirty (30) days of issuance of a notice to return Product. 7.15 If Seller determines that a Product does not conform to Warranty, Seller may elect, in its sole discretion, to repair, replace, or exchange the Product, or credit the original purchase price. In addition, Seller will credit Buyer for standard labor and handling costs (to be agreed case by case) per applicable Product.

7.16 Repair, replacement, exchange, or credit of the original purchase price and standard labor and handling costs are the exclusive remedies under Seller's Warranty. All Products repaired, replaced or exchanged are warranted for a period equal to the greater of: (a) the remainder of the original 5 year Warranty Period or 2 year Warranty that was applicable to the repaired, replaced or exchanged Products, or six (6) months, effective from the date the repaired, replaced or exchanged Products are shipped by Seller.

8 Limitation of Liability

8.1 In no event will Seller be liable for any incidental damages, consequential damages, special damages, punitive damages, statutory damages, indirect damages, loss of shipment, loss of products, loss of profits, loss of revenues, loss of use or damage to brand name, even if informed of the possibility of such damages. Seller's liability for damages arising out of or related to this agreement shall in no case exceed in the aggregate a sum equal to twice the amount actually paid to Seller for the products from which the claim arose. Further, if buyer requires Seller to use a particular supplier or suppliers, then Seller shall have no liability for the supplier(s) performance, nor for any damages caused directly or indirectly by Seller's product to the extent resulting from incorporation of such supplier(s) product. To the extent permitted by applicable law, these limitations and exclusions will apply regardless of whether liability arises from breach of contract, warranty, tort (including but not limited to negligence), by operation of law, or otherwise. Nothing herein, however, is intended to disclaim Seller's liability for personal injury or death caused by defective products to the extent such liability is mandated by law.

9 Place of Jurisdiction and Applicable Law

9.1 The exclusive place of jurisdiction for all disputes arising from these Terms between the parties shall be governed by the laws of the State of Delaware and the parties shall be governed exclusively by the formal and material laws of the Federal and state courts located in the State of Delaware without reference to its conflict of law provisions. All disputes arising hereunder or in connection with Products shall be subject to the exclusive jurisdiction of the courts of the State of Delaware, to which the parties hereby submit themselves.